User's Guide

Publication number E8025-97003
July 2000

For Safety information, Warranties, and Regulatory information, see the pages behind the index.

© Copyright Agilent Technologies 1994-2000
All Rights Reserved

Solutions for the Toshiba TMPR3903

Solutions for the Toshiba Tmpr3903—At a Glance

This manual describes several ways to connect an Agilent Technologies logic analyzer system to your target system. These connections use an analysis probe (or custom probing), plus an emulation module (for an emulation solution).

Analysis Probe

The analysis probe connects your logic analyzer to your target system for state and timing analysis. The analysis probe can be used with an Agilent Technologies 16600A/700A-series logic analysis system. The analysis probe can be purchased alone, or as part of an emulation solution.

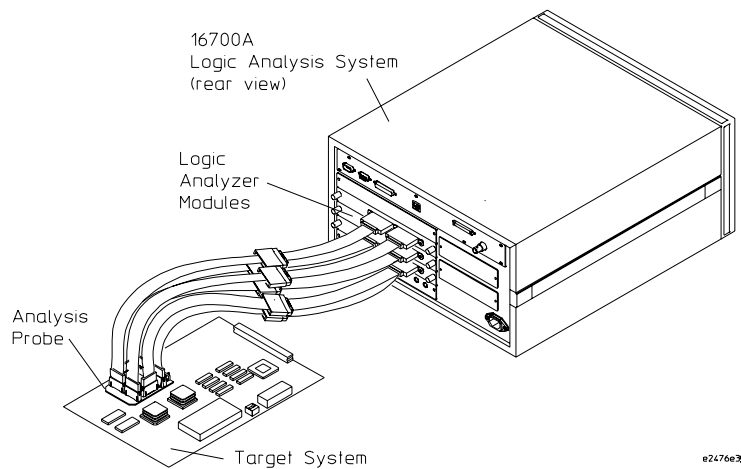

If your target system has the appropriate connectors, you can connect the logic analyzer directly to the target system and use the emulation solution user interface software without the analysis probe.

Emulation Module

The emulation module plugs into your Agilent Technologies 16600A/700A-series logic analysis system frame. The emulation modules lets you use the target processor's built-in background debugging features, including run control and access to registers and memory. A high-level source debugger can use the emulation module to debug code running on the target system. You can connect the emulation module to the analysis probe or you can connect it to a debug port on the target system through the provided target interface module (TIM).

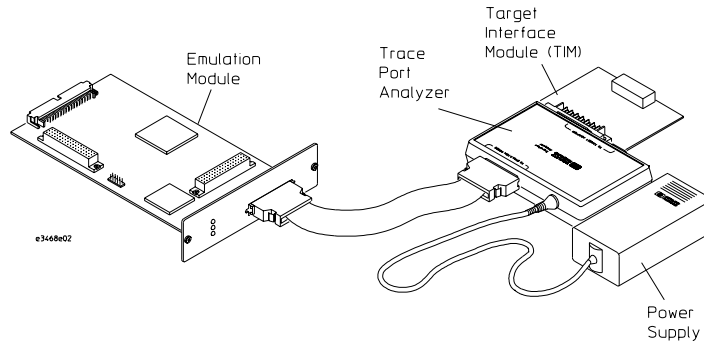

Emulation Solution

The emulation solution includes an analysis probe, an emulation module, a trace port analyzer, cables and adapters, and the Agilent Technologies B3759A Emulation Solution User interface software (For analyzing high-level code). This solution is designed to be used with an Agilent Technologies 16600A/700A-series logic analysis system.

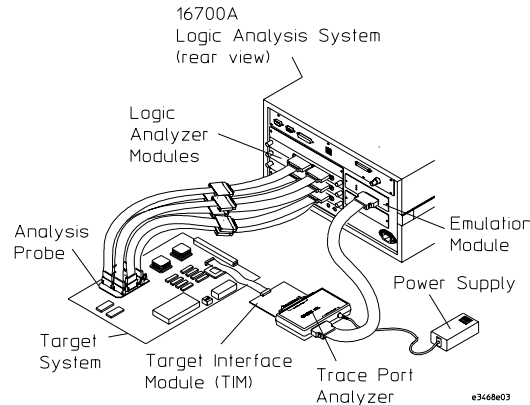

Note

Trace Port Analyzer (E5903A#800) must be used with Emulation Module.

In This Book

This book documents the following products:

Analysis Probe

Processors supported	Agilent Technologies Product ordered	Includes
TMPR 3903	E9600A	E8025A QFP analysis probe and E5346A high density adaptor cables

Emulation Solution

Processors supported	Agilent Technologies Product ordered	Includes
TMPR 3903	E9500A	E8025A QFP analysis probe, 16610A emulation module, E3468A target interface module (TIM), E5890A Trace Port Analyzer, B3759A #800 Emulation Solution User Interface

Contents

1 Overview 11

Setup Flowchart 13

Setup Assistant 14

Analysis Probe 15

Equipment supplied 15

Minimum equipment required 17

Additional equipment supported 17

Logic analyzers supported 18

Logic analyzer software version requirements 19

Emulation Module 20

Equipment supplied 20

Minimum equipment required 21

Trace Port Analyzer 22

Equipment Supplied 22

Minimum equipment required 23

To connect a Trace Port Analyzer to a power source 24

Contents

Emulation Solution 25

Additional Information Sources 26

2 Installing Software on a 16600A/700A 27

To list software packages which are installed (16600A/700A) 29

To install the software from CD-ROM (16600A/700A) 30

3 Setting Up the Analysis Probe 31

Setting Up the Analysis Probe Hardware 33

Turn off the logic analyzer and the target system 33

To connect the Analysis Probe to the target system 34

To disconnect the Analysis Probe from the target system 35

To separate the Analysis Probe upper assembly from the probe head 36

To reconnect Analysis Probe and probe head 36

To connect the high-density adapter cables to the Analysis Probe 37

Setting up the Logic Analyzer 38

Connection Type 'A'

To connect to the 16600/1/2A analyzer 39

Connection Type 'B'

To connect to the 16550A/16710A/16711A/16712A one-card analyzer 40

Connection Type 'C'

To connect to the 16555/56/57A two-cards analyzer 41

4 Designing Connectors for Custom Probing for the B3759A #800 software 43

Direct Probing with GP Probes 45

Designing and Using Built-in Connectors 46

AMP Mictor 38 Connectors 48

Support shroud 49

Connecting the Logic Analyzer to the Target System Connectors 51

5 Installing the Emulation Module 53

To install the emulation module in a 16700A-series logic analysis system or a 16701A expansion frame 55

To install the emulation module in a 16600A-series logic analysis system 57

6 Connecting the Emulator 59

Using the Emulation Control Interface 61

To start the Emulation Control Interface from the main System window (emulation module) 62

To start the Emulation Control Interface from the Workspace window (emulation module) 63

To start the Emulation Control Interface from the Workspace window (emulation probe) 63

Designing a Target System 64

Wiring the N-wire 64

Precautions when you design your target system 66

Connecting the Emulation Module to the Target System 67

To connect to a target system using a debug port 68

To connect to a target system using an analysis probe 70

Contents

To update Firmware	71
To display current firmware version information	71
To update firmware for an emulation module using the Emulation Control Interface	71
To update firmware for an emulation module using the Setup Assistant	72
Configuring the Emulator	73
To configure using the Emulation Control Interface	74
Testing the emulator and target system	75
To test memory accesses	75
To test with a running program	75

7 Hardware Reference 77

Analysis probe-operating characteristics	79
Theory of operation	79
Analysis probe - signal-to-connector mapping	79
Circuit Board Dimensions	84
Emulation Module, Trace Port Analyzer - Operating characteristics	85
Processor Compatibility	85
Emulation Module Electrical Characteristics	86
Trace Port Analyzer Electrical Characteristics	86
Emulation Module Environmental Characteristics	87
Trace Port Analyzer Environmental Characteristics	87

8 Troubleshooting the Analysis Probe 89

Logic Analyzer Problems	91
Intermittent data errors	91
Unwanted triggers	91
No activity on activity indicators	92
No trace list display	92
Analyzer won't power up	92

Analysis Probe Problems 93

- Target system will not boot up 93
- Erratic trace measurements 94
- Capacitive loading 94

State Analysis Problems 95

- No inverse assembly or incorrect inverse assembly 95

Intermodule Measurement Problems 97

- An event wasn't captured by one of the modules 97

Analysis Probe Messages 98

- "Measurement Initialization Error" 98
- "No Configuration File Loaded" 100
- "Selected File is Incompatible" 100
- "Slow or Missing Clock" 100
- "Time from Arm Greater Than 41.93 ms" 101
- "Waiting for Trigger" 101

Returning Parts to Agilent Technologies for Service 102

- To return a part to Agilent Technologies 102
- To obtain replacement parts 103

Cleaning the Instrument 103

9 Troubleshooting the Emulation Module 105

Emulation Module Troubleshooting Guide 107

Status Lights 108

Contents

Emulation Module Built-in Commands	109
To telnet to the emulation module	109
To use the built-in commands	110
Problems with the Target System	112
What to check first	112
To interpret the initial prompt	114
Problems with the LAN Interface	116
If LAN communication does not work	116
If it takes a long time to connect to the network	117
Problems with the Emulation Module	118
To run the built-in performance verification test using the logic analysis system (emulation module only)	118
To run complete performance verification tests using a telnet connection (emulation module only)	119
Problem with the Trace Port Analyzer and TIM	121
To perform the TIM and Trace Port Analyzer PV tests with an emulation probe/module	121
To perform the TIM only PV tests with an emulation probe/module	122
If a performance verification test fails	123
Returning Parts to Agilent Technologies for Service	124
To return a part to Agilent Technologies	124
To obtain replacement parts	125
Cleaning the Instrument	126

Overview

Overview

This chapter describes:

- Setup Checklist
- Equipment used with the analysis probe
- Equipment used with the emulation module
- Equipment used with the trace port analyzer
- Additional information sources

Setup Flowchart

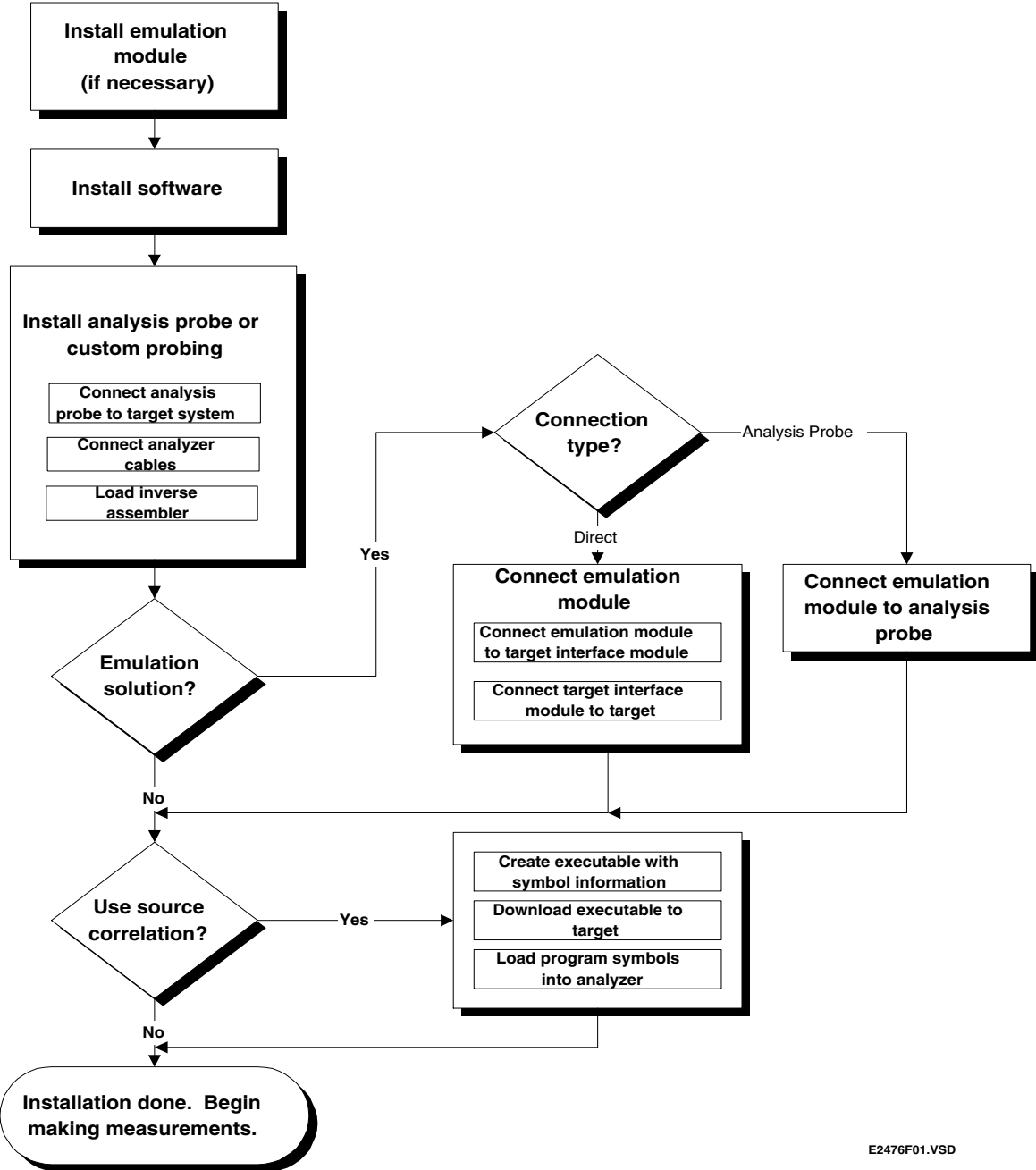

E2476F01.VSD

Setup Assistant

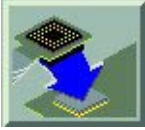

The Setup Assistant is an online tool for connecting and configuring your logic analysis system for microprocessor and bus analysis. The Setup Assistant is available on the Agilent Technologies 16600A and 16700A-series logic analysis systems. You can use the Setup Assistant in place of the connection and configuration procedures provided in this manual.

This menu-driven tool will guide you through the connection procedures for connecting the logic analyzer to an Analysis Probe, an emulation module, or other supported equipment. It will also guide you through connecting an Analysis Probe to the target system.

Start the Setup Assistant by clicking its icon in the system window.

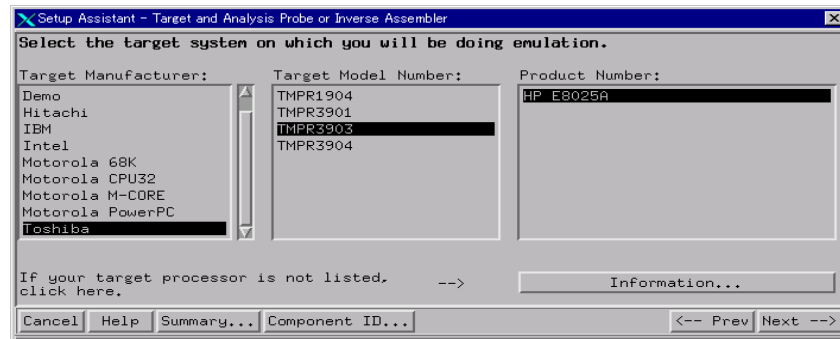

If you ordered this Analysis Probe or emulation solution with your Agilent Technologies 16600A/700A-series logic analysis system, the logic analysis system has the latest software installed, including support for this product. If you received this product after you received your logic analysis system, see the "Installing Software" chapter.

Analysis Probe

This section lists equipment supplied with the analysis probe and equipment requirements for using the analysis probe.

Equipment supplied

The equipment supplied with the analysis probe is shown in the illustration on the next page. It is listed below.

- Agilent Technologies E8025A analysis probe circuit board.
- An elastomeric probe adaptor.
- A retainer kit.
- Three Agilent Technologies E5346A high-density adaptor cables.
- Logic analyzer configuration files on a CDROM (for Agilent Technologies 16600A/700A series logic analysis systems).
- This User's Guide

Analysis Probe

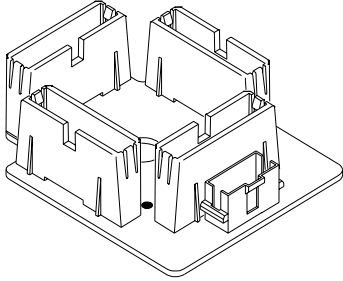

High-Density Termination Cables

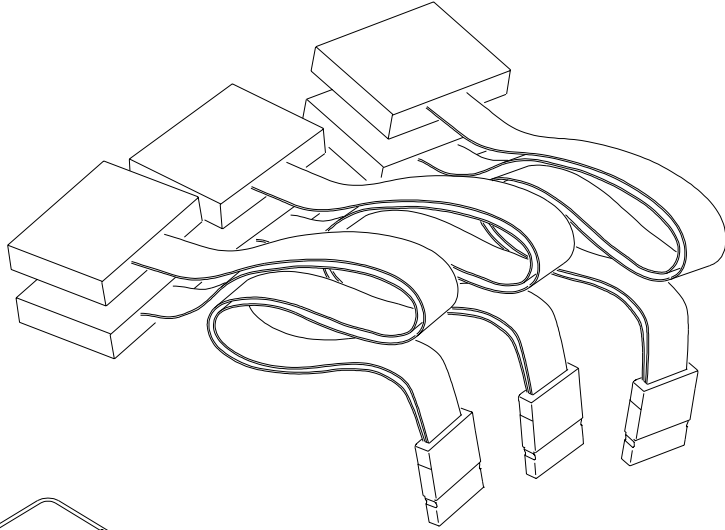

Elastomeric
Probe Adapter

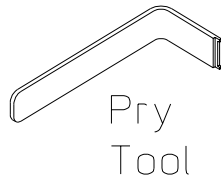
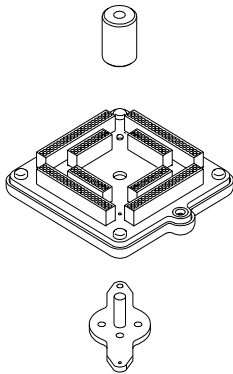

Pry
Tool

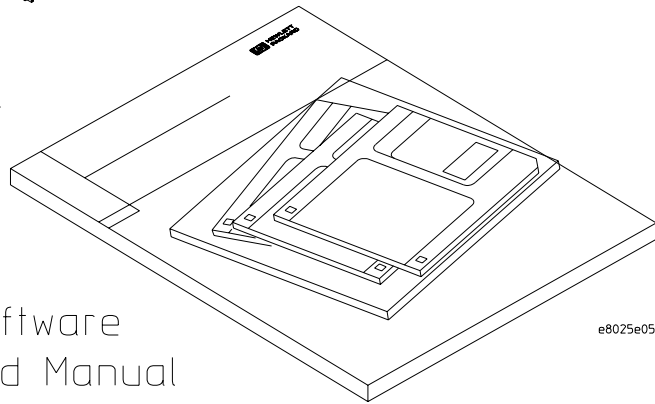

Software
and Manual

e8025e05

Equipment Supplied with the Agilent Technologies E8025A Analysis Probe

Minimum equipment required

For state and timing analysis of an Tmpr3903 target system, you need all of the following items.

- The Agilent Technologies E8025A Analysis Probe.
 - One of the logic analyzers listed on page 20.
-

Additional equipment supported

Emulation module

The Agilent Technologies E8025A has a built-in connector for an Agilent Technologies 16610A emulation module.

Agilent Technologies B3759A #800 Interface Software

The interface software can be used with the analysis probe to control your logic analyzer and inverse assembly of the trace result.

Logic analyzers supported

The table below lists the logic analyzers supported by the Agilent Technologies E8025A analysis probe and B3759A #800 interface software. Logic analyzer software version requirements are shown on the following page.

The Agilent Technologies E8025A and B3759A #800 require six logic analyzer pods (102 channels) for inverse assembly.

Logic Analyzers Supported

Logic Analyzer	Channel Count	State Speed	Timing Speed	Memory Depth
16600A	204	100 MHz	125 MHz	64k states
16601A	136	100 MHz	125 MHz	64k states
16602A	102	100 MHz	125 MHz	64k states
16550A	102/card	100MHz	250MHz	4k states
16710A	102/card	100MHz	250MHz	8k states
16711A	102/card	100MHz	250MHz	32k states
16712A	102/card	100MHz	250MHz	128k states
16555A (two cards)	68/card	110MHz	250MHz	1M states
16555D (two cards)	68/card	110MHz	250MHz	2M states
16556A (two cards)	68/card	100MHz	200MHz	1M states
16556D (two cards)	68/card	100MHz	200MHz	2M states
16557D (two cards)	68/card	135MHz	250MHz	2M states

Logic analyzer software version requirements

The logic analyzer must have the latest software to make a measurement with the Agilent Technologies E8025A. The latest Agilent Technologies 16600A/16700A logic analyzer software version is on the CDROM shipped with this product.

Emulation Module

This section lists equipment supplied with the emulation module and lists the minimum equipment required to use the emulation module.

Equipment supplied

The equipment supplied with your emulation module includes:

- An Agilent Technologies 16610A emulation module. If you ordered an emulation module as part of your Agilent Technologies 16600A or 16700A logic analysis system, it is already installed in the frame.
- A target interface module (TIM) circuit board.
- A emulation module loopback test board (Agilent part number E3496-66502).
- Firmware for the emulation module on a CD-ROM.
- A 50-pin ribbon cable for connecting the emulation module to the target interface module.
- A 20-pin ribbon cable for connecting the target interface module to the target system.
- One Torx T-8, one Torx T-10, and one Torx T-15 screwdriver (if the emulation module was not installed at the factory).
- This User's Guide.

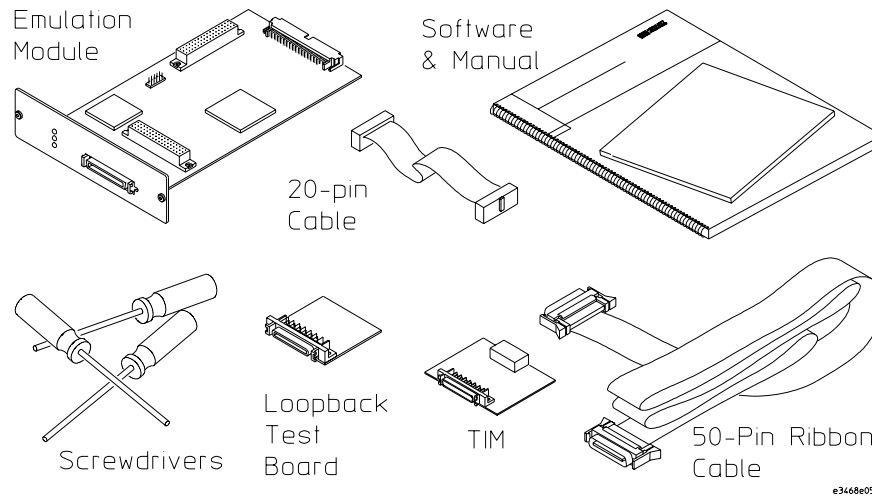

Equipment Supplied with the Agilent Technologies E3468A Emulation Module

Minimum equipment required

The following equipment is required to use the emulation module:

- A method for connecting to the target system. The Agilent Technologies E8025A analysis probe provides a debug port connector. You can also design a debug port connector on the target system.
- An Agilent Technologies 16600A or 16700A logic analysis system.
- E5903A#800 Trace Port Analyzer
- A user interface on the host computer, such as B3759A#800 Emulation Solution Interface or 3rd party's high-level source debugger .

Trace Port Analyzer

This section lists equipment supplied with the trace port analyzer and lists the minimum equipment required to use the trace port analyzer.

Equipment Supplied

The equipment supplied with your trace port analyzer includes:

- Trace Port Analyzer
- A 12V power supply
- DC-DC power code for connection with the Emulation probe
- A trace port analyzer loopback test board (Agilent part number: E5890-66502)

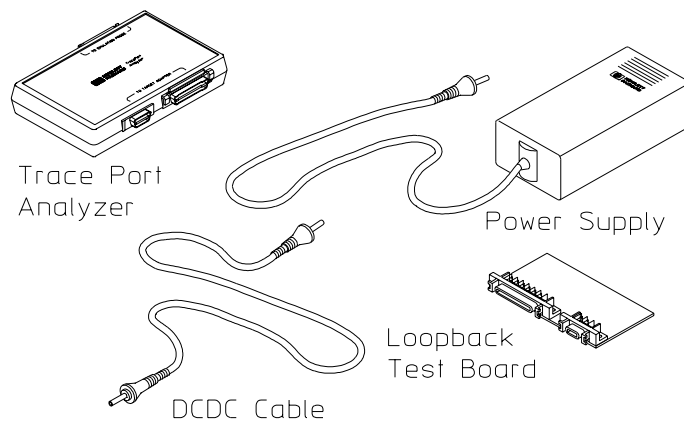

Minimum equipment required

The following equipment is required to use the trace port analyzer:

- An emulation module.
- A 50-pin data cable (supplied with the emulation module or probe).
- A method for connecting to the target system. The Agilent Technologies E8025A analysis probe provides a debug port connector. You can also design a debug port connector on the target system.
- A host computer such as a PC, a workstation, or an Agilent Technologies 16600A or 16700A logic analysis system.
- E5903A#800 Trace Port Analyzer

A user interface on the host computer, such as B3759A#800 Emulation Solution Interface or 3rd party's high-level source debugger .

To connect a Trace Port Analyzer to a power source

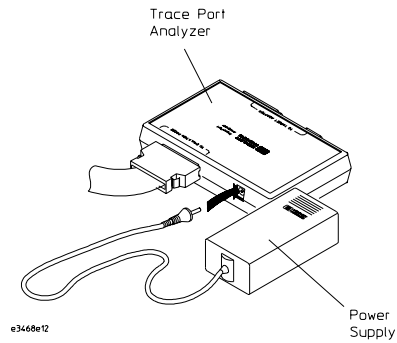

Power-On the logic analyzer first, then connect power to the Trace Port Analyzer.

Emulation Solution

An emulation solution uses the equipment and software already described in this chapter.

The combination of an analysis probe, an emulation module, a trace port analyzer, and an Agilent Technologies 16600A or 16700A logic analysis system lets you both trace and control microprocessor activity on the target system.

The analysis probe supplies signals from the target microprocessor to the logic analyzer. A configuration file sets up the logic analyzer to properly interpret these signals.

You can use a Agilent Technologies B3759A #800 interface software to configure and control the target processor and to download program code.

Additional Information Sources

Additional or updated information can be found in the following places:

Newer editions of this manual may be available. Contact your local Agilent Technologies representative.

If you have an analysis probe, the instructions for connecting the probe to your target microprocessor are in the analysis probe documentation. The ***Solutions for the Toshiba Tx19/39 Series User's Guide*** provides information on using the analysis probe and emulation module together.

Application notes may be available from your local Agilent Technologies representative or on the World Wide Web at:

<http://www.agilent.com/find/logicanalyzer>

The **measurement examples** include valuable tips for making emulation and analysis measurements. You can find the measurement examples under the system help in your Agilent Technologies 16600A/700A logic analysis system.

Installing Software on a 16600A/700A

Installing Software on a 16600A/700A

This chapter explains how to install the software you will need for your analysis probe or emulation solution.

Installing and loading

Installing the software will copy the files to the hard disk of your logic analysis system. Later, you will need to **load** some of the files into the appropriate hardware module.

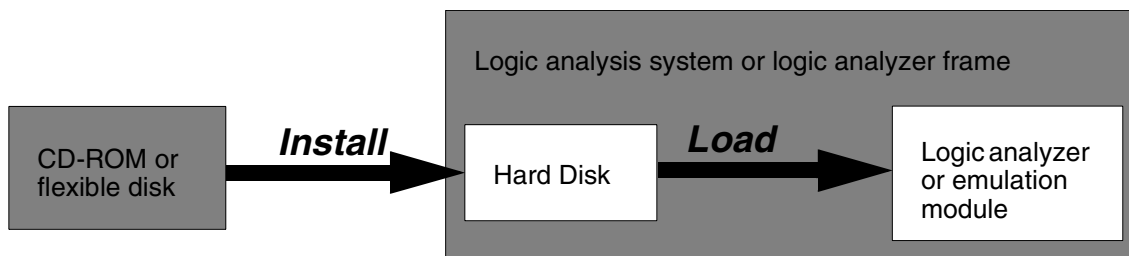

What needs to be installed

Agilent Technologies 16600A/700A-series logic analysis systems

If you ordered an emulation solution with your logic analysis system, the software was installed at the factory.

The following files are installed when you install a processor support package from the CD-ROM:

- Logic analysis system configuration files
- Personality files for the Setup Assistant
- Emulation module firmware

To list software packages which are installed (16600A/700A)

- In the System Administration Tools window, click **List...** .

To install the software from CD-ROM (16600A/700A)

Installing a processor support package from a CD-ROM will take just a few minutes. If the processor support package requires an update to the Agilent Technologies 16600A/700A operating system, installation may take approximately 15 minutes. If the CD-ROM drive is not connected, see the instructions printed on the CD-ROM package.

- 1 Turn on the CD-ROM drive first and then turn on the logic analysis system.
- 2 Insert the CD-ROM in the drive.
- 3 Click the **System Admin** icon.
- 4 Click **Install...** .
Change the media type to "CD-ROM" if necessary.
- 5 Click **Apply**.
- 6 From the list of types of packages, select "PROC-SUPPORT."
A list of the processor support packages on the CD-ROM will be displayed.
- 7 Click on the "Tx19/39" package.
If you are unsure if this is the correct package, click Details for information on what the package contains.
- 8 Click **Install...** .
The dialog box will display "Progress: completed successfully" when the installation is complete.
- 9 Click **Close**.

The configuration files are stored in `/hplogic/configs/hp/processor`.

See Also

The instructions printed on the CD-ROM package for a summary of the installation instructions.

The online help for more information on installing, licensing, and removing software.

Setting Up the Analysis Probe

Setting Up the Analysis Probe

This chapter shows you how to connect the logic analyzer to the target system through the analysis probe. If you are using custom probing, turn to page 44.

Use the Setup Assistant to connect and configure your system (see page 14). Use this manual for additional information, if desired.

If you are not using the Setup Assistant, follow the instructions given in this chapter. This chapter covers the following tasks; the order shown here is the recommended order for performing these tasks.

- Read the power on/off sequence
- Connect the analysis probe to the target system
- Connect the analysis probe to the logic analyzer

Setting Up the Analysis Probe Hardware

Setting up the Analysis Probe hardware consists of the following major steps:

- Turn off the logic analyzer and the target system.
- Connect the Elastomeric Probing System retainer to the target system.
- Attach the Analysis Probe circuit board and adapter to the retainer.
- Attach the labels to the Agilent Technologies E5346A High-Density cables, then connect the cables to the Analysis Probe.
- Connect the logic analyzer pods to the high-density adapter cables.

The remainder of this section describes these general steps in more detail.

Turn off the logic analyzer and the target system

To protect your equipment, remove the power from both the logic analyzer and the target system before you make or break connections. The logic analyzer should always be powered up before the target system. When powering down, power down the target system first and then power down the logic analyzer.

To connect the Analysis Probe to the target system

Use the following steps to connect the Analysis Probe to the target system.

CAUTION

Equipment Damage. To prevent equipment damage, be sure to remove power from both the target system and the logic analyzer whenever the Analysis Probe is being connected or disconnected.

- 1 Turn off the target system and logic analyzer.**
- 2 Using the instructions in the *Agilent Technologies QFP Elastomeric Probing System Installation Guide*:**
 - Prepare to attach the Retainer to the QFP microprocessor
 - Test the alignment before adhering the Retainer
 - Adhere the Retainer to the QFP microprocessor
 - Install the Agilent Technologies E8025A Analysis Probe as described in "Install the Probe Adapter"
- 3 Using the illustration on the next page, note the following indicators:**
 - position of Pin 1 on the microprocessor
 - position of little pin on the retainer
 - position of little hole on the probe adapter

CAUTION

Serious damage to the target system or Analysis Probe can result from incorrect connection. Note the position of pin 1 on the target system and Analysis Probe prior to making any connection. Also, take care to align the pins so that all pins are making contact.

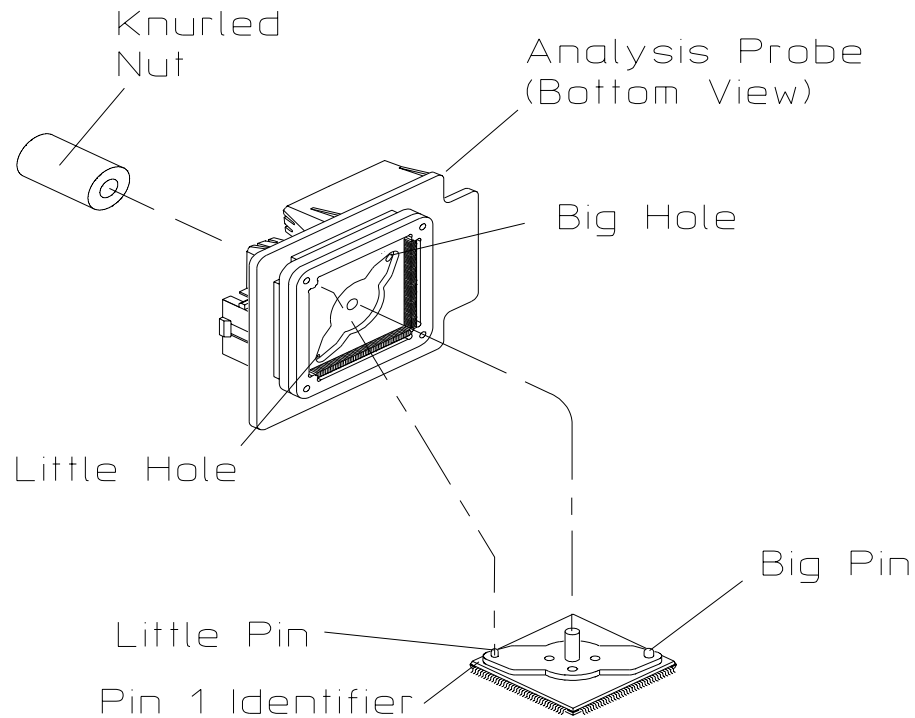

e8025e04

Pin 1 Alignment for Target System and Analysis Probe

To disconnect the Analysis Probe from the target system

Use the following steps to disconnect the Analysis Probe from the target system.

- 1 Remove power from the target system.**
- 2 Remove power from the logic analyzer.**
- 3 Unscrew the knurled nut.**
- 4 Lift the Analysis Probe straight up.**

To separate the Analysis Probe upper assembly from the probe head

Agilent Technologies does not recommend separating the Analysis Probe upper assembly from the elastomeric probe head. However, unforeseen circumstances might require you to separate the assembly.

Use the Cam Tool supplied. Insert the tool into the one side, and rotate it until the connectors begin to separate. Repeat this process for the other three sides in consecutive order until the Analysis Probe upper assembly and the elastomeric probe head are separated.

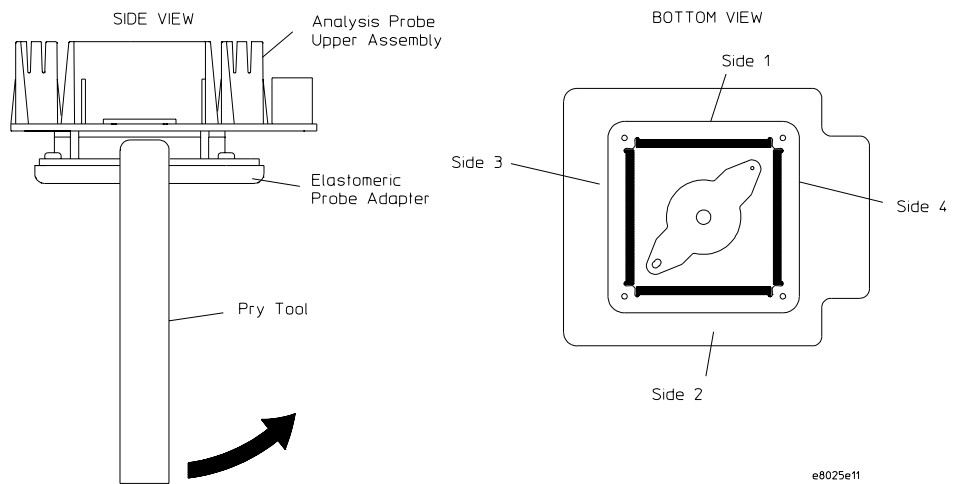

To reconnect Analysis Probe and probe head

Place the elastomeric probe head in its protective cover. Orient the elastomeric probe head and the Analysis Probe upper assembly as shown in the illustration on the previous page. As you begin to insert the pins of the Analysis Probe upper assembly into the sockets on the elastomeric probe head, ensure that all of the pins are engaging. Look closely at both ends of all four sockets to ensure all pins are properly mated. Gently apply pressure until the connectors are fully mated.

To connect the high-density adapter cables to the Analysis Probe

The high-density adapter cables, and labels to identify them, are included with the Agilent Technologies E8025A Analysis Probe. The labels identify the cables by the pod number, and "o" or "e" (for odd or even). Attach the labels to the cables, then connect the cables to the connectors on the Analysis Probes as shown in the following illustrations.

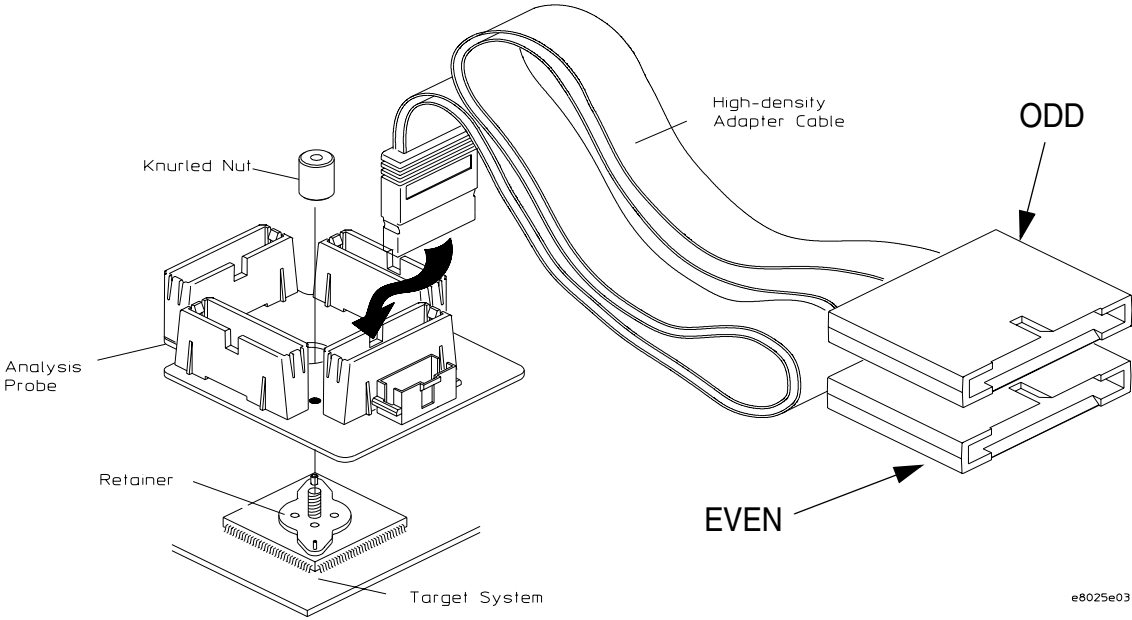

e8025e03

High-Density Adapter Cables

Setting up the Logic Analyzer

Connect the logic analyzer pod cables to the logic analyzer and to the mictor connector on the Analysis Probe. The E8025A analysis probe uses 6 logic analyzer pods. Please refer to your connection type from the table below.

Logic Analyzer	Config File	Connection Type
16600A 16601A 16602A	TX3903F_0 (TX3903F_0H for Half Mode)	A
16700A + 16550A	TX3903F_0 (TX3903F_0H for Half Mode)	B
16700A + 16710/11/12	TX3903F_0 (TX3903F_0H for Half Mode)	B
16700A + 16555/56/57 x 2	TX3903M_0 (TX3903M_0H for Half Mode)	C

Note

If your 16700A Logic Analyzer equips with three card analyzer (One master, and two slave modules) and your connection type is “C”, you must detach one of the slave module on your logic analyzer. (One master, and one slave) Refer to the analyzer manual for the instruction on how to detach the module.

Connection Type 'A' To connect to the 16600/1/2A analyzer

Connect the pod cables to the Analysis Probe according to the pod diagram below.

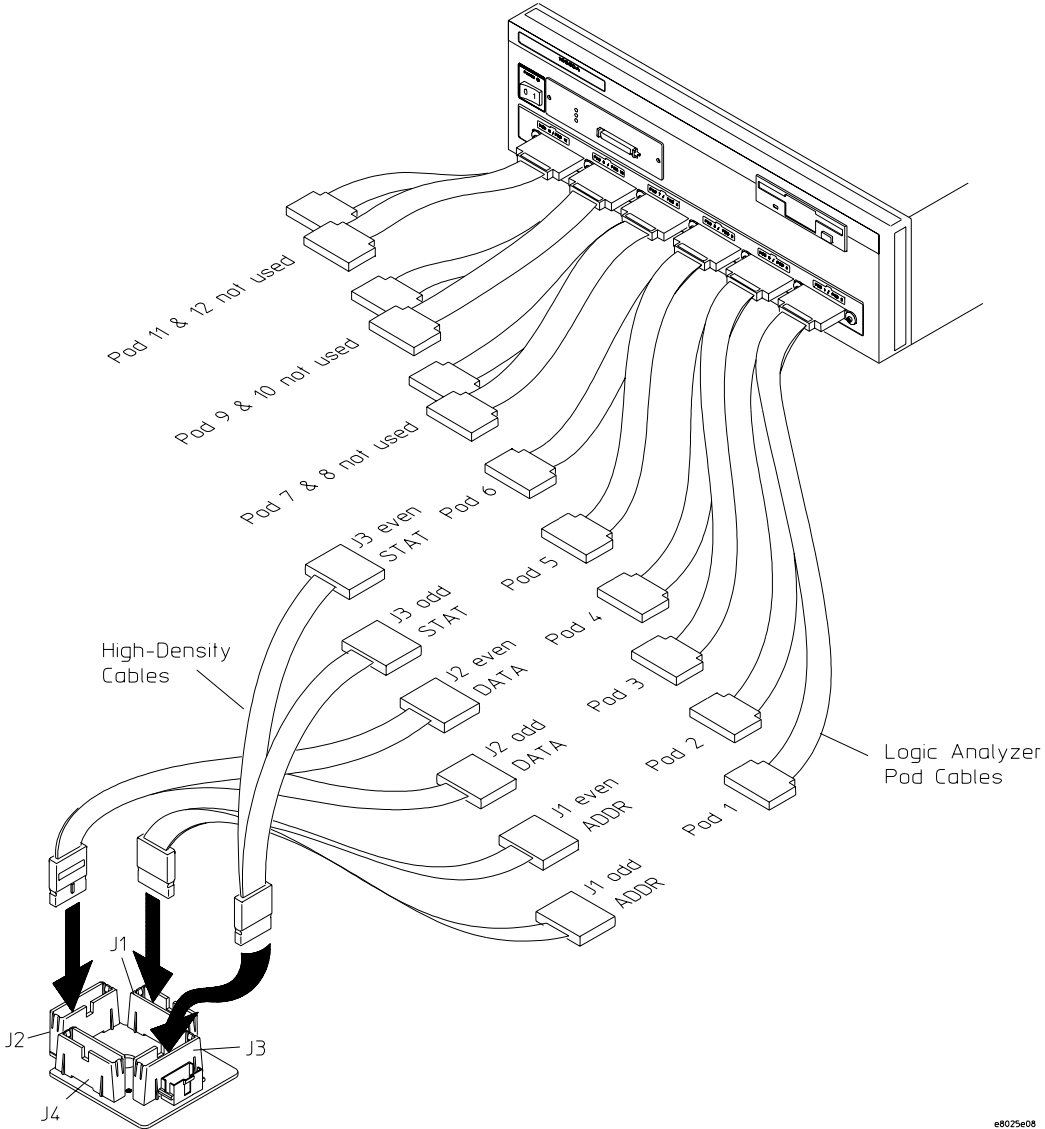

Connection Type 'B' To connect to the 16550A/16710A/16711A/16712A one-card analyzer

Connect the pod cables to the Analysis Probe according to the pod diagram below.

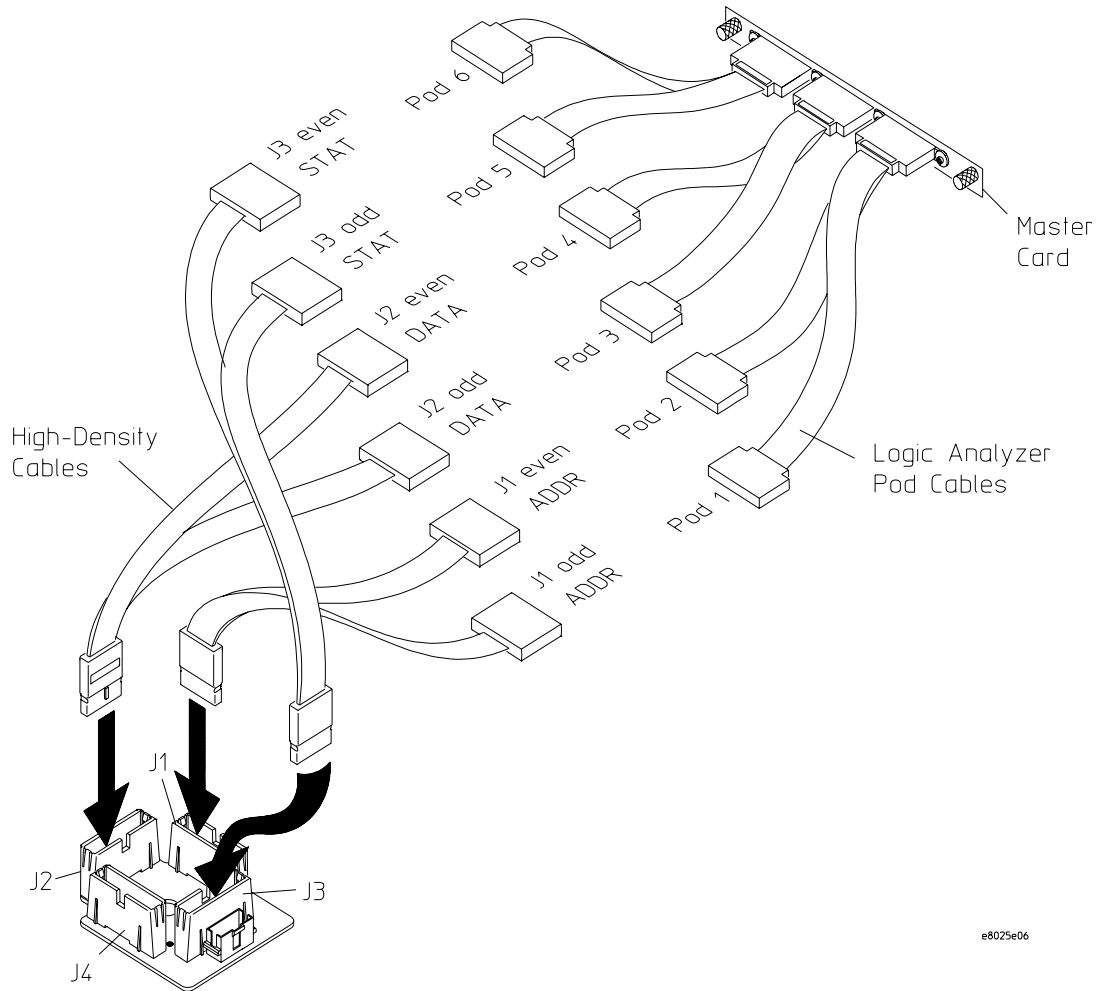

e8025e06

If your analyzer equips two cards of 16550/710/711/712A, connect all the cables above to "Master" module.

Connection Type 'C' To connect to the 16555/56/57A two-cards analyzer

Connect the pod cables to the Analysis Probe according to the pod diagram below.

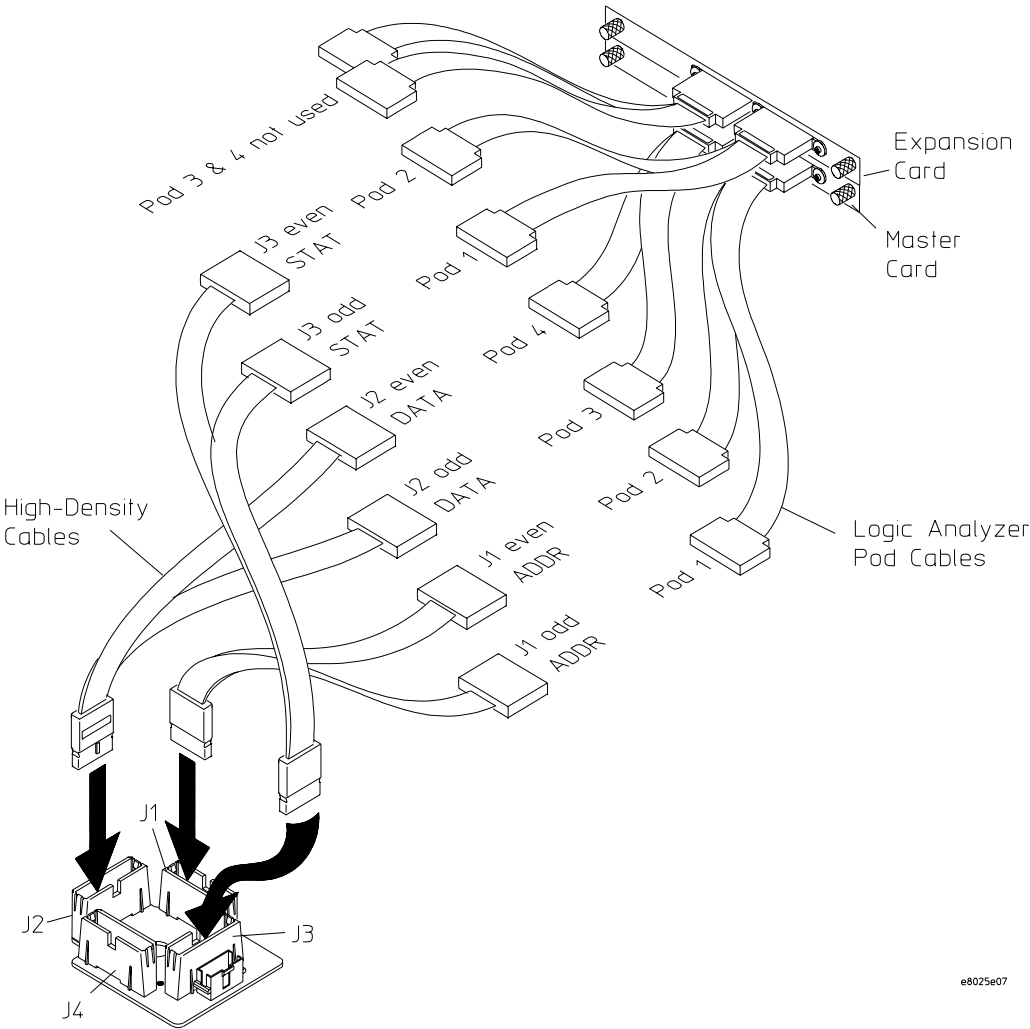

e8025e07

CAUTION

All operations must be done on the Agilent Technologies B3759A (Emulation Interface Software) except for the MSA.

After finishing MSA, don't touch anything on the state analysis listing window, although it pops up. Any changing on this window might cause a fatal error on a Agilent Technologies B3759A (Emulation Interface Software).

You can still operate other modules like analog scope. Also as long as you don't remove a state analysis machine, you can operate a workspace to perform cross domain measurement.

Designing Connectors for
Custom Probing for the B3759A
#800 software

Designing Connectors for Custom Probing for the B3759A #800 software

This chapter shows you how to design logic analyzer connectors on your target system for use with the Agilent Technologies B3759A #800 emulation solution user interface software.

If you are using an Agilent Technologies E8025A analysis probe, skip this chapter.

This chapter consists of the following sections:

- Using the General Purpose (GP) probes
- Designing logic analyzer connectors on your target system for the Agilent Technologies B3759A #800 emulation solution user interface software.

Direct Probing with GP Probes

If you are using general-purpose (GP) probes, connect the individual probes to the signals according to the signal-to-connector mapping tables, as shown in chapter 10. Use the figures in chapter 3 to determine which logic analyzer pods to use for the signal groups.

It is helpful to label the probe headers before installing the probes. You should connect the ground signal for the analyzer clock(s), and two to four signal grounds per pod.

Designing and Using Built-in Connectors

You can design analyzer-compatible connectors into the target board, and connect the logic analyzer cables to these connectors according to the figures in chapter 3. The primary concerns when using built-in connectors are:

- The board real estate required by the connectors
- Ensuring that the logic analyzer connection is properly terminated
- Ensuring that the microprocessor pins connect to the proper logic analyzer probes. See the "Hardware Reference" chapter for pinouts.

The connection scheme shown in this section uses 38-pin connectors on the target system, and high-density termination cables to connect to the logic analyzer. Each connector and cable supports two logic analyzer pods. The part numbers for built-in connectors and cables are shown below. An illustration of the components is shown on the following page.

Part Numbers for Built-in Connectors and Cables

Part Number	Description
Agilent 1252-7431, or AMP 2-767004-2	2 x 19 header. A minimum of three connectors (six logic analyzer pods) is required; up to six may be used.
Agilent E5346-44701	Optional connector-support shroud
Agilent E5346A	High-density termination cable. One required for each 2x19 connector.

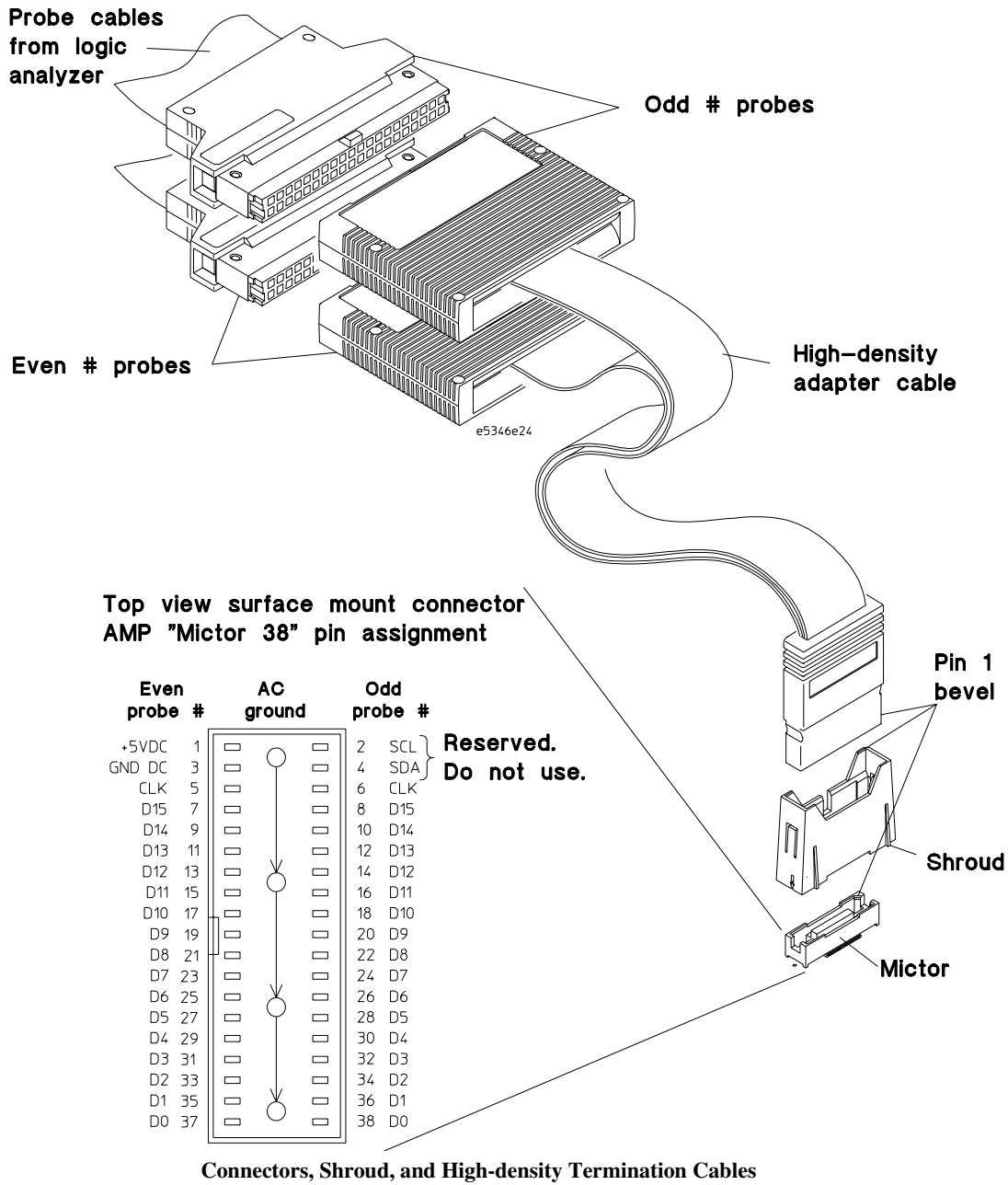

AMP Mictor 38 Connectors

Each Mictor 38 connector carries 32 signals plus two clocks (CLK1 for two logic analyzer pods). The high-density termination cables are required to connect the logic analyzer cables to the connector (Agilent part number E5346A). These cables contain the required termination. One cable is required for every two logic analyzer pods.

The figure on the previous page shows the pinout for a Mictor 38 connector. Refer to the "Hardware Reference" chapter (page <Reference>) for the tables showing the microprocessor signals for each pin. Note that the +5V pin (pin 1) is used to supply power from the logic analyzer to any active devices on an interface board. In most instances, this pin should not be used.

To increase the structural support for the cables, you can also use cable support shrouds (Agilent part number E5346-44701) on each connector. The figures on the following page show the mechanical layouts for the shrouds and headers.

Design Considerations

The connector must be located close enough to the target signal so that the stub length created is less than $\frac{1}{5}$ the T_r (bus risetime, see figure below). For PC board material, ($\epsilon_r = 4.9$) and Z_0 in the range of 50 - 80 Ω , use a propagation delay of 160 ps/inch of stub.

Each probed signal line must be able to supply a minimum of 600 mV to the probe tip and handle a minimum of 90 K Ω shunted by 10 pF. The maximum input voltage to the high-density cables is ± 40 V peak.

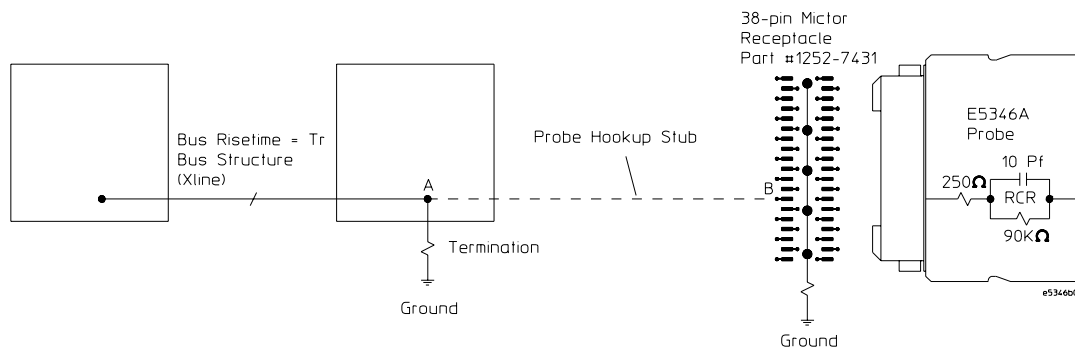

2x19 Header Design Rules

Support shroud

The support shrouds (Agilent part number E5346-44701) provides additional strain relief between the connectors and the high-density termination cables. The shroud requires two through-hole connections to the target board. It fits around the header, and mounts directly to the target board. The following figures show the mechanical connections for the shrouds and connectors.

0.050 in X 0.017 in (1.27 mm X 0.43 mm)
 pad with 0.005 in (0.13 mm) X 45°
 corner chamfers typ 38

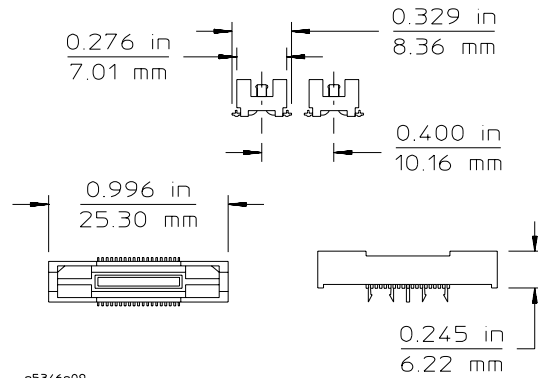
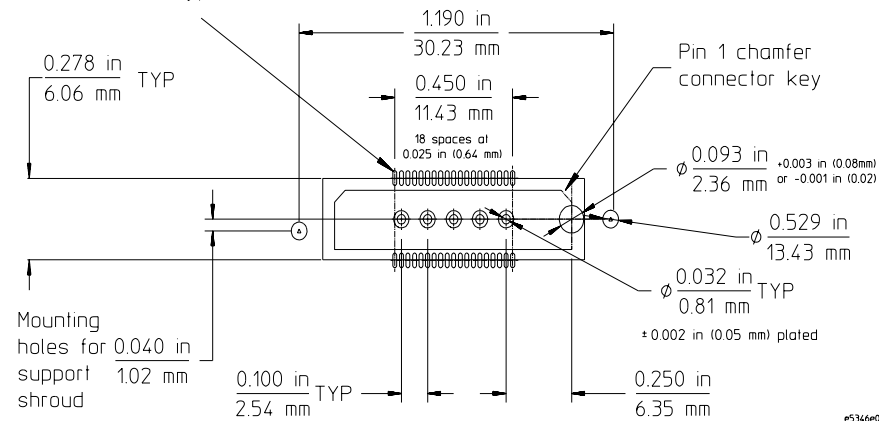

Support Shroud Mechanical Information

Chapter 4: Designing Connectors for Custom Probing for the B3759A #800 software
Designing and Using Built-in Connectors

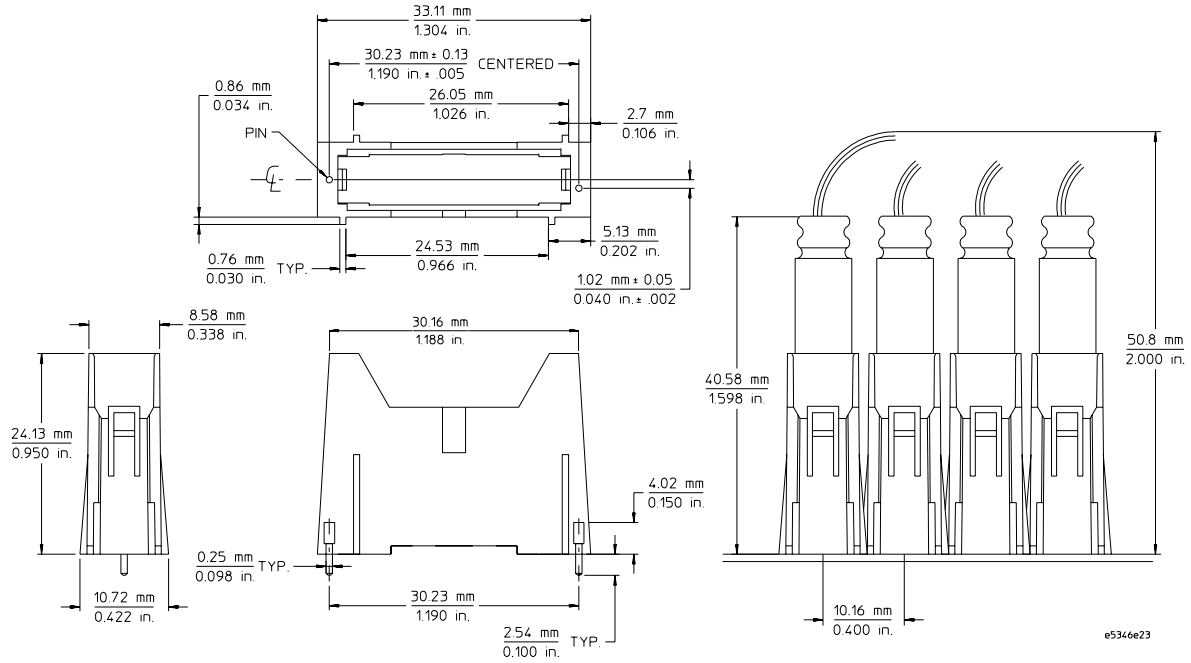

2x19 Header Mechanical Information

Connecting the Logic Analyzer to the Target System Connectors

The procedures for connecting and configuring the logic analyzer are listed in chapter 3.

Installing the Emulation Module

Installing the Emulation Module

This chapter shows you how to install an emulation module in your Agilent Technologies 16600A/700A-series logic analysis system.

If your emulation module is already installed in your logic analysis system frame, you may skip this chapter.

CAUTION

These instructions are for trained service personnel. To avoid dangerous electric shock, do not perform any service unless qualified to do so. Do not attempt internal service or adjustment unless another person, capable of rendering first aid and resuscitation, is present.

Electrostatic discharge can damage electronic components. Use grounded wriststraps and mats when you handle modules.

To install the emulation module in a 16700A-series logic analysis system or a 16701A expansion frame

You will need T-10 and T-15 Torx screw drivers.

- 1 Turn off the logic analysis system and **REMOVE THE POWER CORD**. Remove any other cables (such as probes, mouse, or video monitor).
- 2 Turn the logic analysis system frame upside-down.
- 3 Remove the bottom cover.

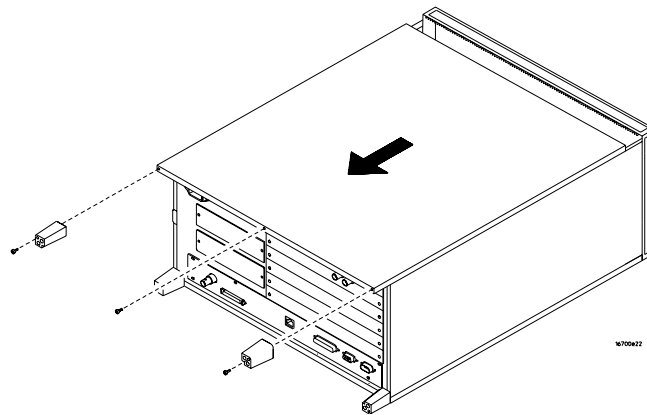

- 4 Remove the slot cover.
You may use either slot.

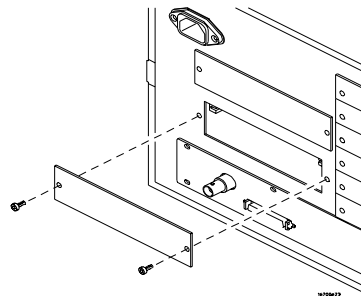

5 Install the emulation module.

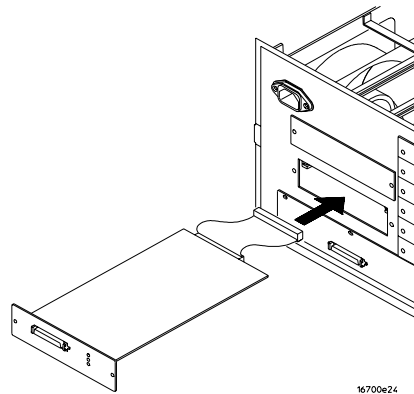

6 Connect the cable and re-install the screws.

You may connect the cable to either of the two connectors. If you have two emulation modules, note that many debuggers will work only with the "first" module: the one toward the top of the frame ("Slot 1"), plugged into the connector nearest the back of the frame.

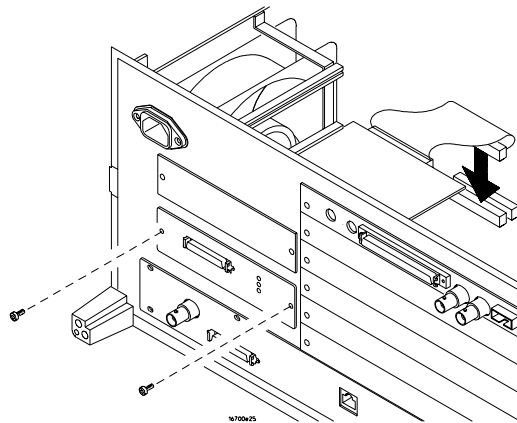

7 Reinstall the bottom cover, then turn the frame right-side-up.

8 Plug in the power cord, reconnect the other cables, and turn on the logic analysis system.

The new emulation module will be shown in the system window.

See Also

See page 14 for information on giving the emulation module a "personality" for your target processor.

To install the emulation module in a 16600A-series logic analysis system

You will need T-8, T-10, and T-15 Torx screw drivers.

- 1 Turn off the logic analysis system and **REMOVE THE POWER CORD**. Remove any other cables (such as probes, mouse, or video monitor).
- 2 Slide the cover back.

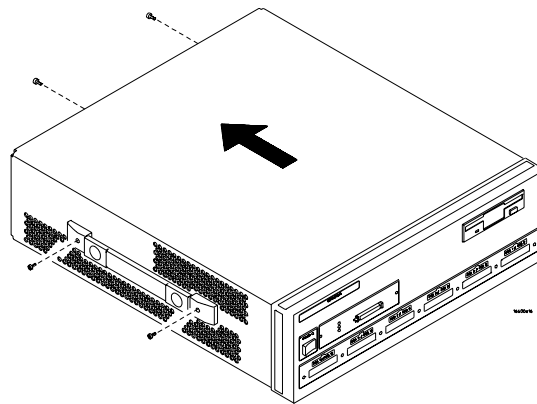

- 3 Remove the slot cover.

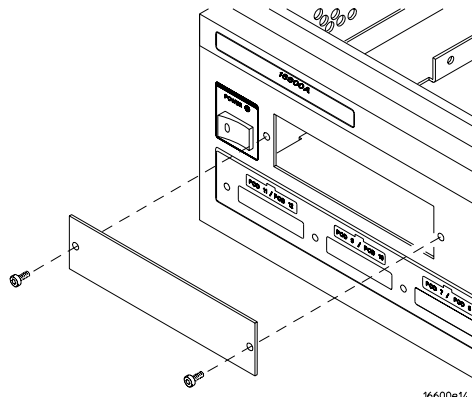

Chapter 5: Installing the Emulation Module
Installing the Emulation Module

- 4 Install the emulation module.
- 5 Connect the cable and re-install the screws.

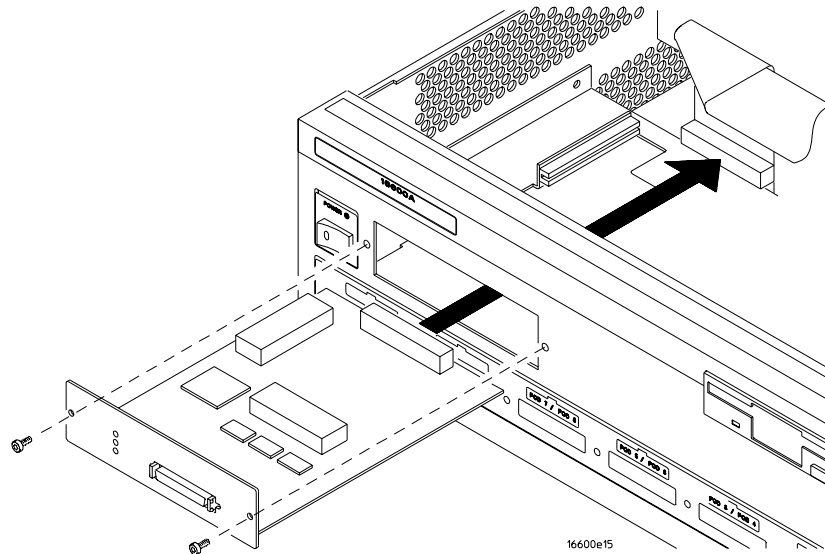

- 6 Reinstall the cover.
Tighten the screws snugly (2 N•m or 18 inch-pounds).
- 7 Plug in the power cord, reconnect the other cables, and turn on the logic analysis system.
The new emulation module will be shown in the system window.

See Also

See page 14 for information on giving the emulation module a "personality" for your target processor.

Connecting the Emulator

Connecting the Emulator

This chapter shows you how to connect the emulator to the target system and how to configure the emulator and target processor.

Overview

Here is a summary of the steps for connecting and configuring the emulator:

- 1 Make sure the target system is designed to work properly with the emulator. (Page 64.)
- 2 Install the emulation module in your logic analysis system, if necessary. (Page 53.)
If you are connecting an emulation module to an Agilent Technologies 16600A/700A-series logic analysis system, use the Setup Assistant to guide you through steps 3-4.
- 3 Connect the emulator to your target system using the 50-pin cable and the TIM or an analysis probe. (Page 67.)
- 4 Update the firmware of the emulator, if necessary. (Page 71.)
- 5 Verify communication between the emulator and the target
- 6 Configure the emulator
- 7 Test the connection between the emulator and the target
- 8 Connect a debugger to the emulator, if applicable.

Using the Emulation Control Interface

The Emulation Control Interface in your Agilent Technologies 16600A/700A-Series logic analysis system allows you to control an emulator (an emulation module or an emulation probe).

As you set up the emulator, you will use the Emulation Control Interface to:

- Update firmware (which preloads or changes the processor-specific personality of the emulator).
- Change the LAN port assignment (rarely necessary).
- Run performance verification tests on the emulator.

The Emulation Control Interface allows you to:

- Run, break, reset, and step the target processor.
- Set and clear breakpoints.
- Read and write registers.
- Read and write memory.
- Read and write I/O memory.
- View memory in mnemonic form.
- Read and write the emulator configuration.
- Download programs (in Motorola S-Record or Intel Hex format) to the target system RAM or ROM.
- View emulator status and errors.
- Write and play back emulator command script files.

If you have an emulation probe, this interface also allows you to configure the LAN address of the emulation probe.

Using the logic analysis system's intermodule bus does not require the Emulation Control Interface to be running. If the emulation module icon is in the Intermodule window, then it will be able to send and receive signals. Therefore if you are using a debugger, you can use an analyzer to cause a break.

Using a debugger with the Emulation Control Interface is not recommended because:

- The interface can get out of synchronization when commands are issued from both interfaces. This causes windows to be out-of-date and can cause confusion.
- Most debuggers cannot tolerate another interface issuing commands and may not start properly if another interface is running.

See Also

All of the Emulation Control Interface windows provide online help with a Help button or a Help->On this window menu selection. Refer to the online help for complete details about how to use a particular window.

To start the Emulation Control Interface from the main System window (emulation module)

- 1 In the System window, click the emulation module icon.
- 2 Select **Start Session...**

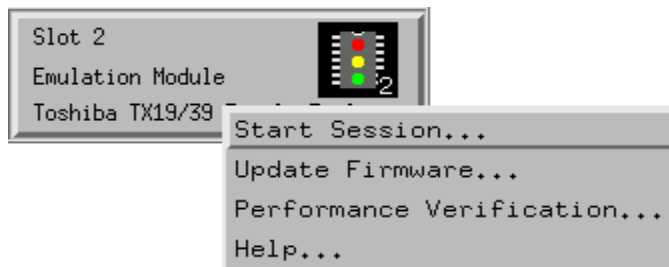

To start the Emulation Control Interface from the Workspace window (emulation module)

- 1 Open the Workspace window.
- 2 Drag the Emulator icon onto the workspace.
- 3 Right-click the Emulator icon, and then select **Start Session...**

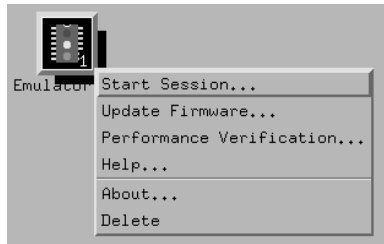

To start the Emulation Control Interface from the Workspace window (emulation probe)

If you have a stand-alone emulation probe connected to the logic analysis system via LAN, use the Emulation Probe icon instead of the Emulation Module icon.

- 1 Open the Workspace window.
- 2 Drag the Emulation Probe icon onto the workspace.
- 3 Right-click the Emulation Probe icon, and select **Start Session...**

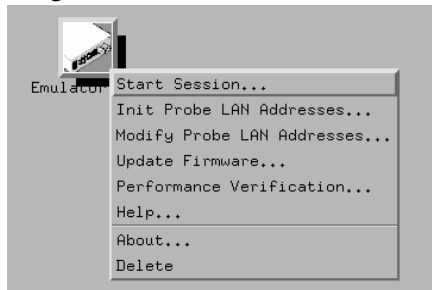

- 4 In the Session window, enter the IP address or LAN name of the emulation probe, then click **Start Session**.

Designing a Target System

This section will help you design a target system that will work with the Agilent Technologies E3468A Emulation Module.

Wiring the N-wire

To connect the Agilent Technologies E5900A #800 Emulation Probe to your target system, you have to prepare the following 20 signals called N-wire on your target system using the 20-pin connector.

N-wire

Cable Pin Number	Signal	TMPR3903 Pin Number
1	RESET	80
3	V _{DD}	79
5	DRESET	78
7	SDI/DINT	77
9	DBGE	76
11	SDA0/TPC	76
13	PCST[0]	74
15	PCST[1]	73
17	PCST[2]	72
19	DLCK	71
Odd Pins	V _{SS}	

Pin assignments for 20-pin connector is the following.

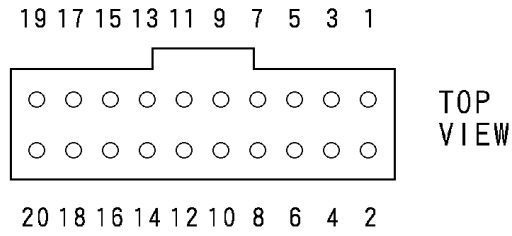

20-pin connector

You can use following connectors.

Supplier	Product Number	Description
AMP	104069-1	Shrouded - Right Angle
AMP	104068-1	Shrouded - Vertical
AMP	104549-2	Shrouded - Vertical (SMT)

Caution

Locate the 20-pin connector within 10cm (4 inches) from the microprocessor on your target system. If the 20-pin connector is located further than 10cm (4 inches) away from the microprocessor, Agilent Technologies E5900A #800 Emulation Probe may not work correctly.

Target V_{DD}

The Agilent Technologies E3468A Emulation Module may draw up to 10 mA from target V_{DD} .

Precautions when you design your target system

You need to pay attention to the following limitations when you design your target system.

CAUTION

While the monitor program is running, the processor's memory access cycles to the monitor area (0xff200000 - 0xff3fffff) cause bus cycles to be driven to the target system. You need to design your target system so that it may not cause errors such as address error at such bus cycles. Refer to the processor manual for the details. See "Glossary" for "monitor program".

CAUTION

You can NOT use debug functions of Tmpr3903 microprocessor, since these functions are reserved for the Agilent Technologies E3468A emulation module only.

Connecting the Emulation Module to the Target System

Choose one of the following methods for connecting the emulation module to a target system.

- Directly through a debug port connector on the target board.
- Through an Agilent Technologies E8025A analysis probe, which provides a direct connection to the debug port pins.

After you have connected the emulation module to your target system, you need to update the firmware with “Setup Assistant” from your logic analyzer.

See Also

For information on designing a debug port on your target board, see page 64.

For a list of the parts supplied with the emulator, see page 20.

To connect to a target system using a debug port

The emulation module can be connected to a target system through a 20-pin debug port. The emulator should be connected to a 20-pin male 2x10 header connector on the target system using the 20-pin conductor cable assembly provided.

- 1 Turn off the target system and disconnect it from all power sources.
- 2 Plug one end of the 50-pin cable into the emulator.

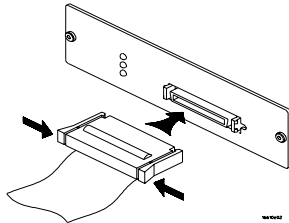

- 3 Plug the other end of the 50-pin cable into the Trace Port Analyzer.
- 4 Plug the target interface module into the Trace Port Analyzer.
- 5 Plug one end of the 20-pin cable into the target interface module.
- 6 Plug the other end of the 20-pin cable into the debug port on the target system.

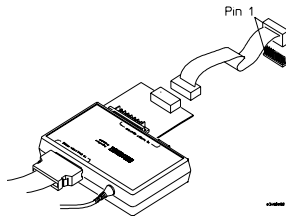

- 7 Turn on the power to the logic analysis system and then the target system.

See Also

"Designing a Target System" (page 64) for information on designing a target system for use with the emulator.

Note

To lock connectors

The Trace Port Analyzer has a aligning lock to prevent the TIM from being disconnected.

1. Loosen the two screws
2. Slide a lock out as shown
3. Connect the TIM.
4. Slide lock in
5. Tighten the screws

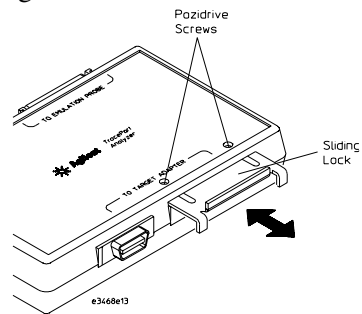

To connect to a target system using an analysis probe

The Agilent Technologies E8025A analysis probe provides a 20-pin connector for direct connection to the debug port pins. You may directly connect your emulation module to this port to control your target system using the 20-pin conductor cable assembly provided.

- 1 Turn off the target system and disconnect it from all power sources.
- 2 Plug one end of the 50-pin cable into the emulation module.

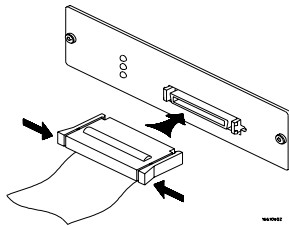

- 3 Plug the other end of the 50-pin cable into the Trace Port Analyzer.
- 4 Plug the target interface module into the Trace Port Analyzer.
- 5 Plug one end of the 20-pin cable into the target interface module.
- 6 Plug the other end of the 20-pin cable into the debug port on the analysis probe.
- 7 Turn on the power to the logic analysis system and then the target system.

To update Firmware

Always update firmware by installing a processor support package. This will ensure that the version of the Emulation Control Interface software is compatible the version of the emulator firmware.

To display current firmware version information

- 1 In the Update Firmware window, click Display Current Version.
There are usually two firmware version numbers: one for “Generics” and one for the personality of your processor.
-

To update firmware for an emulation module using the Emulation Control Interface

- 1 End any run control sessions which may be running.
- 2 In the Workspace window, remove any Emulator icons from the workspace.
- 3 Install the processor support package from the CD-ROM, if necessary.
- 4 In the system window, click the emulation module and select **Update Firmware...**

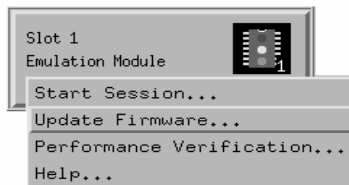

- 5 In the Update Firmware window, select the firmware to load into the emulation module.
- 6 Click **Update Firmware**.
In about 20 seconds, the firmware will be installed and the screen will update to show the current firmware version.

See Also

“Installing Software” beginning on page 38 for instructions on how to install the processor support package from the CD-ROM.

To update firmware for an emulation module using the Setup Assistant

The Setup Assistant is an online tool for connecting and configuring your logic analysis system for microprocessor and bus analysis. The Setup Assistant is available on the Agilent Technologies 16600A and 16700A-series logic analysis systems.

This menu-driven tool will guide you through the connection procedures for connecting the logic analyzer to an analysis probe, an emulation module, or other supported equipment. It will also guide you through connecting an analysis probe to the target system.

Do not use the Setup Assistant to connect an emulation probe if you already have an emulation module installed.

- 1 Install the processor support package from the CD-ROM.
- 2 Start the Setup Assistant by clicking its icon in the system window.

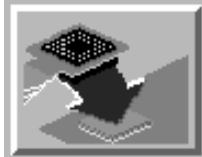

- 3 Follow the instructions displayed by the Setup Assistant.

See Also

Page 29 for instructions on how to install a the processor support package from the CD-ROM.

Configuring the Emulator

The emulator has several user-configurable options. These options may be customized for specific target systems and saved in configuration files for future use.

The easiest way to configure the emulator is through the Emulation Control Interface in an Agilent Technologies 16600A or 16700A logic analysis system.

If you use the Emulation Control Interface, please refer to the online help in the Configuration window for information on each of the configuration options.

You may also use the emulator configuration window of your debugger (B3759A #800) to configure your emulator.

To configure using the Emulation Control Interface

The easiest way to configure the emulators is to use the Emulation Control Interface.

1 Start an Emulation Control Interface session.

From an emulation module:

- In the system window, click the Emulation Control Interface icon, and then select “Start Session...”.

For an emulation probe:

- In the workspace window, drag the emulation probe icon onto the workspace, and then select “Start Session...”.

2 Open a Configuration window.

Select “Configuration...” from the Emulation Control Interface icon or from the Navigate menu in any Emulation Control Interface window.

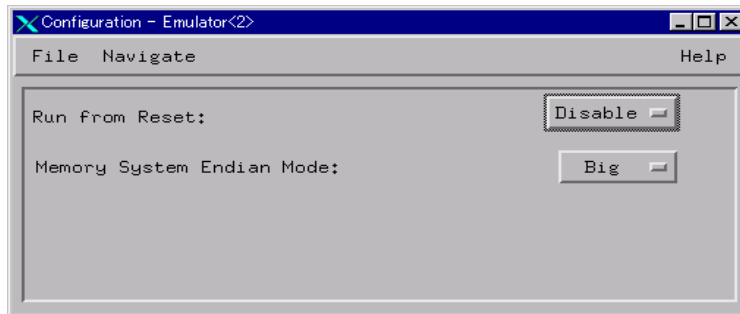

3 Set the configuration options, as needed.

The configuration selections will take effect when you close the configuration window or when you move the mouse pointer outside the window.

4 Save the configuration settings.

To save the configuration settings, open the File Manager window and click **Save....**

See Also

Help->**Help on this window** in the Configuration window for information on each of the configuration options.

Help in the Emulation Control Interface menu for help on starting an Emulation Control session.

Testing the emulator and target system

After you have connected and configured the emulator, you should perform some simple tests to verify that everything is working.

See Also

“Troubleshooting the Emulator” on page 105 for information on testing the emulator hardware.

To test memory accesses

- 1 Start the Emulation Control Interface and configure the emulator, if necessary.
 - 2 Open the Memory window.
 - 3 Write individual locations or fill blocks of memory with patterns of your choosing.
The access size is the size of memory access that will be used to write or read the memory values.
 - 4 Use the Memory I/O window to stimulate I/O locations by reading and writing individual memory locations.
-

To test with a running program

To more fully test your target, you can load simple programs and execute them.

- 1 Compile or assemble a small program and store it in a Motorola S-Record or Intel Hex file.
 - 2 Use the Load Executable window to download the program into RAM or flash memory.
 - 3 Use the Breakpoints window to set breakpoints. Use the Registers window to initialize register values.
The new register or breakpoint values are sent to the processor when you press the Enter key or when you move the cursor out of the selected register field.
 - 4 In the Run Control window, click Run.
 - 5 Use the Memory Mnemonic window to view the program and use the Memory window to view any output which has been written to memory.
-

Hardware Reference

Hardware Reference

This chapter contains additional reference information including the specifications and characteristics for the analysis probe and the emulation probe, as well as signal mapping for the Agilent Technologies E8025A analysis probe and the B3759A #800 software. It consists of the following information:

- Analysis probe reference
- Emulation module reference
- Trace Port Analyzer reference

Analysis probe-operating characteristics

The following operating characteristics are not specifications, but are typical operating characteristics for the Agilent Technologies E8025A TMR3903 analysis probe.

Product Characteristics

Microcontroller Supported	Toshiba TMR3903
Package Supported	208-pin QFP
Pods Required	8, or 10 logic analyzer pods (four high-density adapter cables) are required for disassembly depending on your target system's memory Two high-density adapter cables are available for additional signal analysis.

Electrical Characteristics

Power Requirements	None.
Signal Line Loading	10pF, 100 kohms on all signals.

Environmental Characteristics

Temperature	Operating	0 to + 50 degrees C +32 to +131 degrees F
Altitude	Operating	4,600 m 15,000 feet
Humidity		Up to 75% noncondensing. Avoid sudden, extreme temperature changes which could cause condensation on the circuit board.

Theory of operation

The Agilent Technologies E8025A analysis probe is a passive probe. All signals are routed through to the logic analyzer without passing through any additional circuitry.

Analysis probe - signal-to-connector mapping

The following tables show the electrical signal-to-connector mapping implemented by the Agilent Technologies E8025A TMR3903 Analysis Probe and the B3759A #800 interface software.

TMPR3903 Signal List

Connector	Analyzer Bit	TMPR3903 Pin #	Signal Name	Analyzer Label
J1odd (6)	CLK1	44	FCLK	
J1odd (8)	15	84	A15	
J1odd (10)	14	85	A14	
J1odd (12)	13	86	A13	
J1odd (14)	12	87	A12	
J1odd (16)	11	88	A11	
J1odd (18)	10	91	A10	
J1odd (20)	9	92	A9	
J1odd (22)	8	93	A8	
J1odd (24)	7	94	A7	
J1odd (26)	6	95	A6	
J1odd (28)	5	98	A5	
J1odd (30)	4	99	A4	
J1odd (32)	3	100	A3	
J1odd (34)	2	101	A2	
J1odd (36)	1	167	DREQ1	
J1odd (38)	0	169	DREQ0	
J1even (5)	CLK1	41	SYSCLK	
J1even (7)	15	62	A31	
J1even (9)	14	63	A30	
J1even (11)	13	64	A29	
J1even (13)	12	65	A28	
J1even (15)	11	66	A27	
J1even (17)	10	67	A26	
J1even (19)	9	68	A25	
J1even (21)	8	71	A24	
J1even (23)	7	72	A23	
J1even (25)	6	73	A22	
J1even (27)	5	74	A21	
J1even (29)	4	75	A20	
J1even (31)	3	76	A19	
J1even (33)	2	77	A18	
J1even (35)	1	82	A17	
J1even (37)	0	83	A16	

Connector	Analyzer Bit	TMPR3903 Pin #	Signal Name	Analyzer Label	Analyzer Label
J2odd (6)	CLK1	168	DACK0		
J2odd (8)	15	125	D15		
J2odd (10)	14	126	D14		
J2odd (12)	13	127	D13		
J2odd (14)	12	130	D12		
J2odd (16)	11	131	D11		
J2odd (18)	10	132	D10		
J2odd (20)	9	133	D9		
J2odd (22)	8	134	D8		
J2odd (24)	7	135	D7		
J2odd (26)	6	138	D6		
J2odd (28)	5	139	D5		
J2odd (30)	4	140	D4		
J2odd (32)	3	143	D3		
J2odd (34)	2	144	D2		
J2odd (36)	1	145	D1		
J2odd (38)	0	148	D0		
J2even (5)	CLK1	166	DACK1		
J2even (7)	15	102	D31		
J2even (9)	14	103	D30		
J2even (11)	13	106	D29		
J2even (13)	12	107	D28		
J2even (15)	11	108	D27		
J2even (17)	10	109	D26		
J2even (19)	9	110	D25		
J2even (21)	8	111	D24		
J2even (23)	7	112	D23		
J2even (25)	6	115	D22		
J2even (27)	5	116	D21		
J2even (29)	4	117	D20		
J2even (31)	3	118	D19		
J2even (33)	2	122	D18		
J2even (35)	1	123	D17		
J2even (37)	0	124	D16		

Chapter 7: Hardware Reference
Analysis probe - signal-to-connector mapping

Connector	Analyzer Bit	TMPR3903 Pin #	Signal Name	Analyzer Label	Analyzer Label
J3odd (6)	CLK1	1	Vcc		
J3odd (8)	15	7	BURST		
J3odd (10)	14	202	CS5		
J3odd (12)	13	203	CS4		
J3odd (14)	12	204	CS3		
J3odd (16)	11	205	CS2		
J3odd (18)	10	206	CS1/RAS1		
J3odd (20)	9	207	CS0/RAS0		
J3odd (22)	8	4	WR		
J3odd (24)	7	3	RD		
J3odd (26)	6	6	BSTART		
J3odd (28)	5	5	LAST		
J3odd (30)	4	36	ACK		
J3odd (32)	3	8	BE3		
J3odd (34)	2	11	BE2		
J3odd (36)	1	12	BE1		
J3odd (38)	0	13	BE0		
J3even (5)	CLK1	190	DOTCLK		
J3even (7)	15	191	HSYNC		
J3even (9)	14	192	VSYNC/CSYNC		
J3even (11)	13	193	HDISP		
J3even (13)	12	194	CAS3		
J3even (15)	11	195	CAS2		
J3even (17)	10	196	CAS1		
J3even (19)	9	197	CAS0		
J3even (21)	8	26	RESET		
J3even (23)	7	14	BUSGNT		
J3even (25)	6	16	HALT		
J3even (27)	5	31	HALF		
J3even (29)	4	32	ENDIAN		
J3even (31)	3	33	BUSREQ		
J3even (33)	2	34	SNOOP		
J3even (35)	1	35	BUSERR		
J3even (37)	0	37	NMI		

Connector	Analyzer Bit	TMPR3903 Pin #	Signal Name	Analyzer Label	Analyzer Label
J4odd (6)	CLK1	45	CLKEN		
J4odd (8)	15	170	PIO15		
J4odd (10)	14	171	PIO14		
J4odd (12)	13	172	PIO13		
J4odd (14)	12	173	PIO12		
J4odd (16)	11	174	PIO11		
J4odd (18)	10	175	PIO10		
J4odd (20)	9	176	PIO9		
J4odd (22)	8	177	PIO8		
J4odd (24)	7	180	PIO7		
J4odd (26)	6	181	PIO6		
J4odd (28)	5	182	PIO5		
J4odd (30)	4	183	PIO4		
J4odd (32)	3	184	PIO3		
J4odd (34)	2	185	PIO2		
J4odd (36)	1	186	PIO1		
J4odd (38)	0	187	PIO0		
J4even (5)	CLK1	149	EXT2		
J4even (7)	15	150	EXT1		
J4even (9)	14	151	EXT0		
J4even (11)	13	152	TXD3		
J4even (13)	12	153	RXD3		
J4even (15)	11	154	TXD2		
J4even (17)	10	155	RXD2		
J4even (19)	9	156	CTS1		
J4even (21)	8	157	RTS1		
J4even (23)	7	158	TXD1		
J4even (25)	6	159	RXD1		
J4even (27)	5	160	CTS0/SECLK		
J4even (29)	4	161	RTS0		
J4even (31)	3	162	TXD0/SEOUT		
J4even (33)	2	163	RXD0/SEIN		
J4even (35)	1	40	FCLKEN		
J4even (37)	0	27	DOZE		

Circuit Board Dimensions

The following figure gives the dimensions for the Analysis Probe assembly. The dimensions are listed in millimeter.

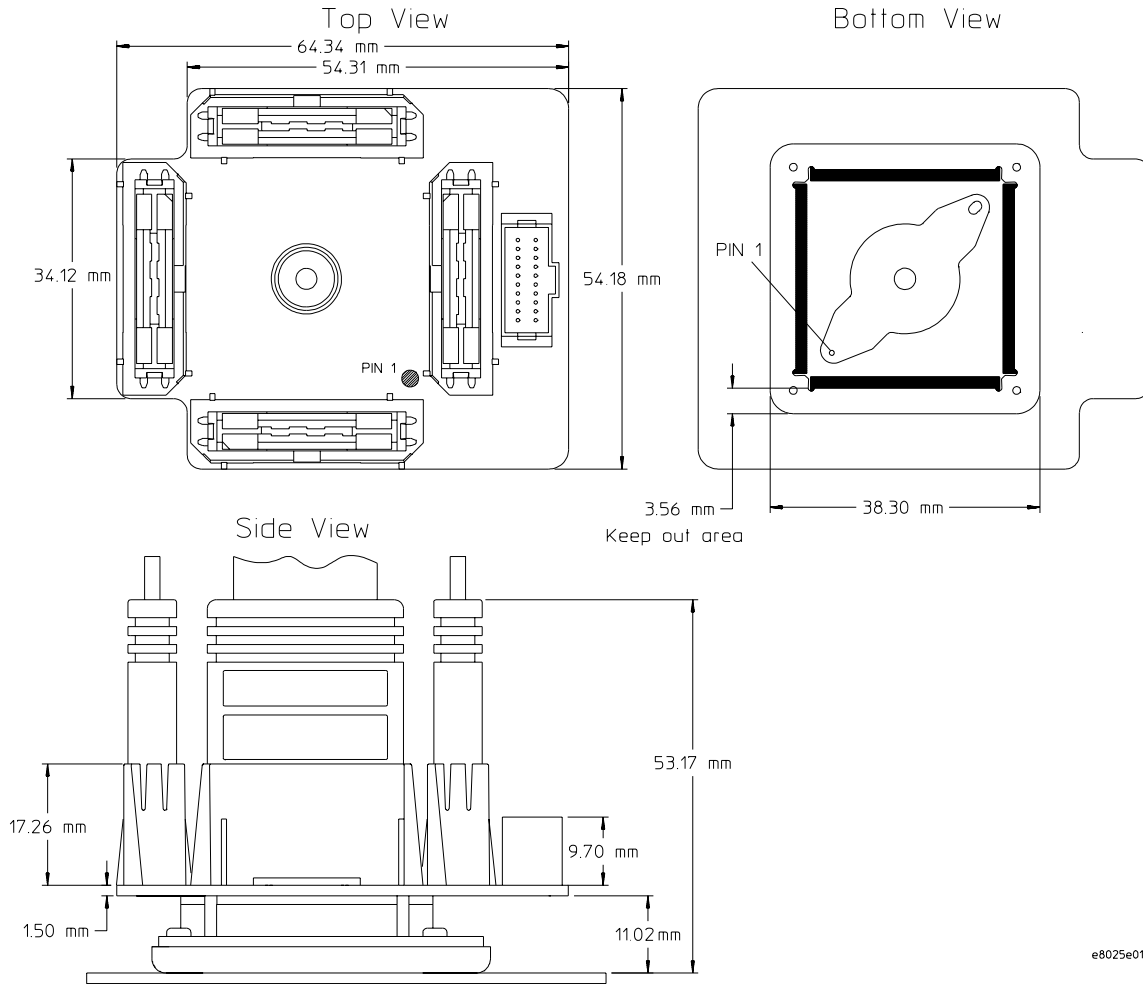

e8025e01

Emulation Module, Trace Port Analyzer - Operating characteristics

The following operating characteristics are not specifications, but are typical operating characteristics for the Agilent Technologies 16610A emulation module, trace port analyzer, and TX19/39 target interface module.

Processor Compatibility

The Agilent Technologies E3468A Tx19/39 Series emulator supports the TMPR 1904, 3901, 3903 and 3904 microprocessors.

Emulation Module Electrical Characteristics

Maximum Ratings

Characteristics for the Tx19/39 Embedded MIPS	Notes	Symbol	Min	Max	Unit
Input voltage range		V_{in}	-0.5	5.5	V
Input voltage range (V _{tt})			1.3	1.7	V
Input High Voltage		V_{ih}	$\frac{2}{3}V_{tt} + 0.2$		V
Input Low Voltage		V_{il}		$\frac{2}{3}V_{tt} - 0.2$	V
Input High Current		I_{ih}		-15	μ A
Input Low Current		I_{il}		100	μ A
Output High Voltage		V_{oh}	2.4	3.3	V
Output Low Voltage		V_{ol}		0.5	V
Output High Current		I_{oh}	8		mA
Output Low Current		I_{ol}	-16		mA

Trace Port Analyzer Electrical Characteristics

Characteristics for the Tx19/39 Trace Port Analyzer	Notes	Symbol	Min	Max	Unit
Input voltage range			-0.5	5.5	V
Input High Voltage			2.0		V
Input Low Voltage				0.7	V
Input High Current				-32	mA
Input Low Current				32	mA
Output High Voltage			2.4		V
Output Low Voltage				0.45	V
Output High Current			25		mA
Output Low Current			-25		mA

Emulation Module Environmental Characteristics

The Agilent Technologies 16610A emulation module meets the environmental characteristics of the logic analysis system in which it is installed.

For indoor use only.

Trace Port Analyzer Environmental Characteristics

Temperature

Operating, 0 to +40 °C (+32 to +104 °F); nonoperating, -40 to +60 °C (-40 to +140 °F).

Altitude

Operating/nonoperating 4600 m (15 000 ft).

Relative Humidity

15% to 95%.

For indoor use only.

Troubleshooting the Analysis Probe

Troubleshooting the Analysis Probe

If you encounter difficulties while making measurements, use this chapter to guide you through some possible solutions. Each heading lists a problem you may encounter, along with some possible solutions.

If you still have difficulty using the analyzer after trying the suggestions in this chapter, please contact your local Agilent Technologies service center.

CAUTION

When you are working with the analyzer, be sure to power down both the analyzer and the target system before disconnecting or connecting cables, probes, and analysis probes. Otherwise, you may damage circuitry in the analyzer, analysis probe, or target system.

Logic Analyzer Problems

This section lists general problems that you might encounter while using the logic analyzer.

Intermittent data errors

This problem is usually caused by poor connections, incorrect signal levels, or marginal timing.

- Remove and reseat all cables and probes, ensuring that there are no bent pins on the analysis probe interface or poor probe connections.
- Adjust the threshold level of the data pod to match the logic levels in the system under test.
- Use an oscilloscope to check the signal integrity of the data lines.

Clock signals for the state analyzer must meet particular pulse shape and timing requirements. Data inputs for the analyzer must meet pulse shape and setup and hold time requirements.

See Also

See “Capacitive Loading” in this chapter for information on other sources of intermittent data errors.

Unwanted triggers

Unwanted triggers can be caused by instructions that were fetched but not executed.

- Add the prefetch queue or pipeline depth to the trigger address to avoid this problem.

The logic analyzer captures prefetches, even if they are not executed. When you are specifying a trigger condition or a storage qualification that follows an instruction that may cause branching, an unused prefetch may generate an unwanted trigger.

No activity on activity indicators

- Check for loose cables, board connections, and analysis probe interface connections.
 - Check for bent or damaged pins on the analysis probe.
-

No trace list display

If there is no trace list display, it may be that your trigger specification is not correct for the data you want to capture, or that the trace memory is only partially filled.

- Check your trigger sequencer specification to ensure that it will capture the events of interest.
 - Try stopping the analyzer; if the trace list is partially filled, this should display the contents of trace memory.
-

Analyzer won't power up

If logic analyzer power is cycled when the logic analyzer is connected to a target system or emulation probe that remains powered up, the logic analyzer may not be able to power up. Some logic analyzers are inhibited from powering up when they are connected to a target system or emulation probe that is already powered up.

- Disconnect all logic analyzer cabling from the analysis probe. This will allow the logic analyzer to power up. Reconnect logic analyzer cabling after power up.

Analysis Probe Problems

This section lists problems that you might encounter when using an analysis probe. If the solutions suggested here do not correct the problem, you may have a damaged analysis probe. Contact your local Agilent Technologies Sales Office if you need further assistance.

Target system will not boot up

If the target system will not boot up after connecting the analysis probe interface, the microprocessor (if socketed) or the analysis probe interface may not be installed properly, or they may not be making electrical contact.

- Ensure that you are following the correct power-on sequence for the analysis probe and target system.
 - 1 Power up the analyzer and analysis probe.
 - 2 Power up the target system.If you power up the target system before you power up the analysis probe, interface circuitry in the analysis probe may latch up and prevent proper target system operation.
- Verify that the microprocessor and the analysis probe interface are properly rotated and aligned, so that the index pin on the microprocessor (pin A1) matches the index pin on the analysis probe interface.
- Verify that the microprocessor and the analysis probe interface are securely inserted into their respective sockets.
- Verify that the logic analyzer cables are in the proper sockets of the analysis probe interface and are firmly inserted.

Erratic trace measurements

- Do a full reset of the target system before beginning the measurement.
Some analysis probe designs require a full reset to ensure correct configuration.
 - Ensure that your target system meets the timing requirements of the processor with the analysis probe installed.
See “Capacitive loading” in this chapter. While analysis probe loading is slight, pin protectors, extenders, and adapters may increase it to unacceptable levels. If the target system design has close timing margins, such loading may cause incorrect processor functioning and give erratic trace results.
 - Ensure that you have sufficient cooling for the microprocessor.
Ensure that you have ambient temperature conditions and airflow that meet or exceed the requirements of the microprocessor manufacturer.
-

Capacitive loading

Excessive capacitive loading can degrade signals, resulting in incorrect capture by the analysis probe interface, or system lockup in the microprocessor. All analysis probe interfaces add additional capacitive loading, as can custom probe fixtures you design for your application.

Careful layout of your target system can minimize loading problems and result in better margins for your design. This is especially important for systems that are running at frequencies greater than 50 MHz.

- Remove as many pin protectors, extenders, and adapters as possible.
- If multiple analysis probe interface solutions are available, use one with lower capacitive loading.

State Analysis Problems

This section lists problems that you might encounter while using the B3759A #800 emulation solution user interface software.

When you obtain incorrect inverse assembly results, it may be unclear whether the problem is in the analysis probe or in your target system. If you follow the suggestions in this section to ensure that you are using the analysis probe and inverse assembler correctly, you can proceed with confidence in debugging your target system.

No inverse assembly or incorrect inverse assembly

This problem may be due to incorrect synchronization, modified configuration, incorrect connections, or a hardware problem in the target system. A locked status line can cause incorrect or incomplete inverse assembly.

- Ensure that each logic analyzer pod is connected to the correct analysis probe connector.

There is not always a one-to-one correspondence between analyzer pod numbers and analysis probe cable numbers. Analysis Probes must supply address (ADDR), data (DATA), and status (STAT) information to the analyzer in a predefined order. The cable connections for each analysis probe are often altered to support that need. Thus, one analysis probe might require that you connect cable 2 to analyzer pod 2, while another will require you to connect cable 5 to analyzer pod 2. See Chapter 3 for connection information.

- Check the activity indicators for status lines locked in a high or low state.
- Verify that the STAT, DATA, and ADDR format labels have not been modified from their default values.

These labels must remain as they are configured by the configuration file. Do not change the names of these labels or the bit assignments within the labels. Some analysis probes also require other data labels. See Chapter 3 for more information.

- Verify that all microprocessor caches have been disabled.

In most cases, if the microprocessor caches remain enabled you should still get inverse assembly. It may be incorrect because a portion of the execution trace was not visible to the logic analyzer.

Chapter 8: Troubleshooting the Analysis Probe
State Analysis Problems

- Verify that storage qualification has not excluded storage of all the needed opcodes and operands.

Intermodule Measurement Problems

Some problems occur only when you are trying to make a measurement involving multiple modules.

An event wasn't captured by one of the modules

If you are trying to capture an event that occurs very shortly after the event that arms one of the measurement modules, it may be missed due to internal analyzer delays. For example, suppose you set an oscilloscope module to trigger upon receiving a trigger signal from the logic analyzer because you are trying to capture a pulse that occurs right after the analyzer's trigger state. If the pulse occurs too soon after the analyzer's trigger state, the oscilloscope will miss the pulse.

- Adjust the skew in the Intermodule menu.

You may be able to specify a skew value that enables the event to be captured.

- Change the trigger specification for modules upstream of the one with the problem.

If you are using a logic analyzer to trigger an oscilloscope module, try specifying a trigger state one state before the one you are using. This may be more difficult than working with the skew because the prior state may occur more often and not always be related to the event you are trying to capture with the oscilloscope.

Analysis Probe Messages

This section lists some of the messages that the analyzer displays when it encounters a problem.

“Measurement Initialization Error”

This error occurs when you have installed the cables incorrectly for one or two Agilent Technologies 16550A logic analysis cards. The following diagrams show the correct cable connections for one-card and two-card installations. Ensure that your cable connections match the silk screening on the card, and that they are fully seated in the connectors. Then, repeat the measurement.

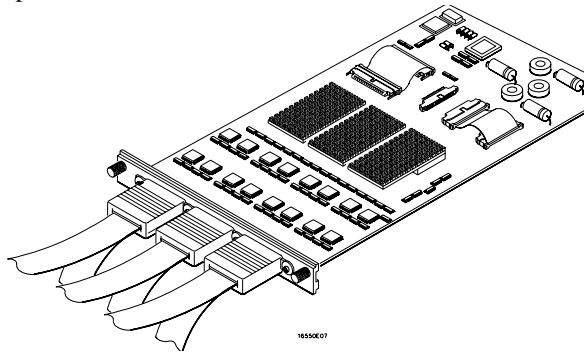

Cable Connections for One-Card Agilent Technologies 16550A Installations

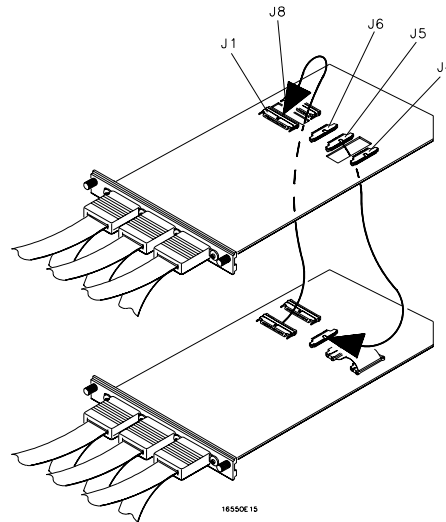

Cable Connections for Two-Card Agilent Technologies 16550A Installations

See Also

The Agilent Technologies 16550A 100-MHz State/500-MHz Timing Logic Analyzer Service Guide.

“No Configuration File Loaded”

This is usually caused by trying to load a configuration file for one type of module/system into a different type of module/system.

- Verify that the appropriate module has been selected from the Load {module} from File {filename} in the disk operation menu. Selecting Load {All} will cause incorrect operation when loading most analysis probe interface configuration files.

See Also

Chapter 2 describes how to load configuration files.

“Selected File is Incompatible”

This occurs when you try to load a configuration file for the wrong module. Ensure that you are loading the appropriate configuration file for your logic analyzer.

“Slow or Missing Clock”

- This error message might occur if the logic analyzer cards are not firmly seated in the logic analysis system frame. Ensure that the cards are firmly seated.
- This error might occur if the target system is not running properly. Ensure that the target system is on and operating properly.
- If the error message persists, check that the logic analyzer pods are connected to the proper connectors on the analysis probe interface. See Chapter 2 to determine the proper connections.

“Time from Arm Greater Than 41.93 ms”

The Agilent Technologies 16550A state/timing analyzers have a counter to keep track of the time from when an analyzer is armed to when it triggers. The width and clock rate of this counter allow it to count for up to 41.93 ms before it overflows. Once the counter has overflowed, the system does not have the data it needs to calculate the time between module triggers. The system must know this time to be able to display data from multiple modules on a single screen.

“Waiting for Trigger”

If a trigger pattern is specified, this message indicates that the specified trigger pattern has not occurred. Verify that the triggering pattern is correctly set.

- When analyzing microprocessors that fetch only from word-aligned addresses, if the trigger condition is set to look for an opcode fetch at an address not corresponding to a word boundary,

Returning Parts to Agilent Technologies for Service

The repair strategy for this emulation solution is board replacement.

Exchange assemblies are available when a repairable assembly is returned to Agilent Technologies. These assemblies have been set up on the "Exchange Assembly" program. This lets you exchange a faulty assembly with one that has been repaired, calibrated, and performance verified by the factory. The cost is significantly less than that of a new assembly.

To return a part to Agilent Technologies

- 1 Follow the procedures in this chapter to make sure that the problem is caused by a hardware failure, not by configuration or cabling problems.
- 2 Call your nearest Agilent Technologies sales office. Ask them for the address of the nearest Agilent Technologies service center.
- 3 Package the part and send it to the Agilent Technologies service center.
Keep any parts which you know are working. For example, if only the target interface module is broken, keep the emulation module and cables.
- 4 When the part has been replaced, it will be sent back to you.
The unit returned to you will have the same serial number as the unit you sent to Agilent Technologies.

To obtain replacement parts

The following table lists some parts that may be replaced if they are damaged or lost. Contact your nearest Agilent Technologies Sales Office for further information.

Analysis Probe Replaceable Parts

Agilent Part Number	Description
E5346A	High-density Cable
E8025-66501	Analysis Probe Circuit Board
E5350-23801	Cam Tool
E5322-60001	Retainer Kit
E5322-23803	Locator Tool
5081-7799	208 pin QFP Elastomeric Probe

Cleaning the Instrument

If the instrument requires cleaning:

- 1** Remove power from the instrument.
- 2** Clean the instrument with a mild detergent and water.
- 3** Make sure that the instrument is completely dry before reconnecting it to a power source.

Chapter 8: Troubleshooting the Analysis Probe
Cleaning the Instrument

Troubleshooting the Emulation Module

Troubleshooting the Emulation Module

If you have problems with the emulation module, your first task is to determine the source of the problem. Problems may originate in any of the following places:

- The connection between the emulation module and your debugger
- The emulation module itself
- The connection between the emulation module and the Trace Port Analyzer
- The connection between the Trace Port Analyzer and the Target interface module
- The connection between the target interface module and the target system
- The target system

You can use several means to determine the source of the problem:

- The troubleshooting guide on the next page
- The status lights on the emulation probe or emulation module
- The emulator "performance verification" tests
- The Trace Port Analyzer "performance verification" tests
- The emulator's built-in "terminal interface" commands

Emulation Module Troubleshooting Guide

Common problems and what to do about them

Symptom	What to do	See also
Commands from debugger have no effect	Your debugger may not be configured properly. If this does not work, continue with the steps for the next symptom....	page 109
Emulation module built-in commands do not work	<p>1 Run the emulation module performance verification tests.</p> <p>2 If the performance verification tests pass, then there is an electrical problem with the connection to the target processor OR the target system may not have been designed according to "Designing a Target System."</p>	page 118 page 64, page 112
"Slow or missing clock" message after a logic analyzer run	Check that the target system is running user code or is in reset. (This message can appear if the processor is in background mode.)	
Host computer reports LAN connection problems	Follow the checklist in the "If you have LAN problems" section.	page 116
Commands from the Run Control tool or debugger have no effect	Verify LAN communication.	page 109

Status Lights

Emulation Module Status Lights

The emulation module uses status lights to communicate various modes and error conditions.

The following table gives more information about the meaning of the power and target status lights.

- = LED is off
- = LED is on
- * = Not applicable (LED is off or on)

Power/Target Status Lights

Pwr/Target LEDs	Meaning
<input type="radio"/> Reset <input type="radio"/> Break <input type="radio"/> Run	No target system power, or emulation module is not connected to the target system
<input checked="" type="radio"/> Reset <input type="radio"/> Break <input type="radio"/> Run	Target system is in a reset state
<input type="radio"/> Reset <input checked="" type="radio"/> Break <input type="radio"/> Run	The target processor is executing in Debug Mode
<input type="radio"/> Reset <input type="radio"/> Break <input checked="" type="radio"/> Run	The target processor is executing user code
<input type="radio"/> Reset <input checked="" type="radio"/> Break <input checked="" type="radio"/> Run	Only boot firmware is good (other firmware has been corrupted)

Emulation Module Built-in Commands

The emulation module has some built-in "terminal interface" commands which you can use for troubleshooting. You can access the terminal interface using:

- A telnet (LAN) connection
- A "debugger command" window in your debugger

To telnet to the emulation module

You can establish a telnet connection to the emulation module if:

- A host computer and the logic analysis system are both connected to a local-area network (LAN), and
- The host computer has the telnet program (often part of the operating system or an internet software package).

To establish a telnet connection:

- 1** Find out the port number of the emulation module.

The default port number of the first emulation module in an Agilent Technologies 16600A/700A series logic analysis system is 6472. The default port of a second module in an Agilent Technologies 16600A-series system is 6476. The default port numbers of a third and fourth module in an expansion frame are 6480 and 6484. These port numbers can be changed, but that is rarely necessary.

- 2** Find out the LAN address or LAN name of the logic analysis system.
- 3** Start the telnet program.

If the LAN name of the logic analysis system is "test2" and you have only one emulation module installed, the command might look like this:

```
telnet test2 6472
```

- 4** If you do not see a prompt, press the <Return> key a few times.

To exit from this telnet session, type <CTRL>D at the prompt.

To use the built-in commands

Here are a few commonly used built-in commands:

Useful built-in commands

b	Break -- go into the background monitor state
cf	Configuration -- read or write configuration options
help	Help -- display online help for built-in commands
init	Initialize -- init -c re-initializes everything in the emulation module except for the LAN software; init -p is the equivalent of cycling power (it will break LAN connections)
lan	configure LAN address
m	Memory -- read or write memory
reg	Register -- read or write a register
r	Run -- start running user code
rep	Repeat -- repeat a command or group of commands
rst	Reset -- reset the target processor (the emulation module will wait for you to press the target's RESET button)
s	Step -- do a low-level single step
ver	Version -- display the product number and firmware version of the emulation module

The prompt indicates the status of the emulation module:

Emulation module prompts

U	Running user program
M	Running in background monitor
p	No target power
R	Emulation reset
r	Target reset
?	Unknown state

Examples

To set register R0, then view R0 to verify that it was set, enter:

```
R>rst -m
M>reg r0=ffff
M>reg r0
   reg R0=0000ffff
```

To break execution then step a single instruction, enter:

```
M>b
M>s
   PC=xxxxxxxx
M>
```

To determine what firmware version is installed in the emulation module, enter:

```
M>ver
```

See Also

Use the `help` command for more information on these and other commands. Note that some of commands listed in the help screens are generic commands for Agilent Technologies emulators and may not be available for your product.

If you are writing your own debugger, contact Agilent Technologies for more information.

Problems with the Target System

This section describes how to determine whether your target system is causing problems with the operation of the emulation module.

What to check first

- 1 Try some basic built-in commands using the Command Line window or a telnet connection:

```
U>rst  
R>
```

This should reset the target and display a "R>" prompt.

```
R>b  
M>
```

This should stop the target and display an "M>" prompt.

```
M>reg r1  
    reg r1=00000000  
M>
```

This should read the value of the r1 register (the value will probably be different on your target system).

```
M>m 0..  
00000000  7c3043a6 7c2802a6 7c3143a6 4bf04111  
00000010  00000000 00000000 00000000 00000000  
00000020  00000000 00000000 00000000 00000000  
00000030  00000000 00000000 00000000 00000000  
00000040  00000000 00000000 00000000 00000000  
00000050  00000000 00000000 00000000 00000000  
00000060  00000000 00000000 00000000 00000000  
00000070  00000000 00000000 00000000 00000000  
M>
```

This should display memory values starting at address 0.

```
M>s
```

This should execute one instruction at the current program counter.

If any of these commands don't work, there may be a problem with the design of your target system, a problem with the revision of the emulation you are using, or a problem with the configuration of the emulation module. The following steps will help you identify the problem.

- 2 Check that the emulation module firmware matches your processor. To do this, enter:

```
M>>ver
```

See Also

Page 109 for information on entering built-in commands.

To interpret the initial prompt

The initial prompt can be used to diagnose several common problems. To get the most information from the prompt, follow this procedure:

- 1 Connect the emulation module to your target system.
- 2 Set the default configuration settings. Enter:

```
M>init -c
```

You can enter this command at any prompt. The emulation module will respond with the same information as printed by the "ver" command.

If the response is "!ERROR 905! Driver firmware is incompatible with ID of attached device"

Make sure the target interface module is connected to the cable of the emulation module, then try the "init -c" command again.

If the initial prompt is "p>"

Check pin 3 on header.

If the initial prompt is "M>"

The processor entered debug mode without the help of the emulation module. Is another debugger connected?

If the initial prompt is "U>"

The emulation module is scanning the instruction register correctly. Now you can do some more tests:

- 4 Enter the reset command:

```
U>rst  
R>
```

The "R>" prompt is a good response that indicates SRESET and HRESET are working.

Problems with the LAN Interface

If LAN communication does not work

If you cannot verify connection using the procedure in "To verify LAN communication", or if the commands are not accepted by the emulation module:

- Make sure that you wait for the power-on self test to complete before connecting.
- Make sure that the LAN cable is connected. Watch the LAN LED's on the back of the logic analysis system to see whether the system is seeing LAN activity. Refer to your LAN documentation for testing connectivity.
- Check that the host computer or debugger was configured with the correct LAN address. If the logic analysis system is on a different subnet than the host computer, check that the gateway address is correct.
- Make sure that the logic analysis system's IP address is set up correctly.

If it takes a long time to connect to the network

- ❑ Check the subnet masks on the other LAN devices connected to your network. All of the devices should be configured to use the same subnet mask.

Subnet mask error messages do not indicate a major problem. You can continue using the emulation module.

The subnet mask is set in the logic analysis system's System Admin window. If it then detects other subnet masks, it will generate error messages.

If there are many subnet masks in use on the local subnet, the logic analysis system may take a very long time to connect to the network after it is turned on.

Problems with the Emulation Module

Occasionally you may suspect a hardware problem with the emulation module or target interface module. The procedures in this section describe how to test the hardware, and if a problem is found, how to repair or replace the broken component.

To run the built-in performance verification test using the logic analysis system (emulation module only)

- 1 End any Emulation Control Interface or debugger sessions.
- 2 Disconnect the 50-pin cable from the emulation module, and plug the loopback test board (Agilent part number E3496-66502) into the emulation module.

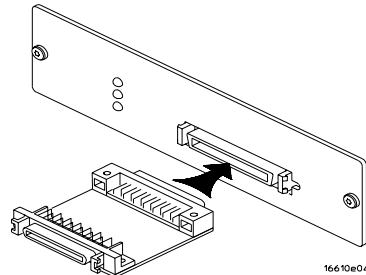

- 3 In the system window, click the emulation module and select **Performance Verification**.
- 4 Click **Start PV**.
The results will appear on screen.

To run complete performance verification tests using a telnet connection (emulation module only)

- 1 Disconnect the 50-pin cable from the emulation module, and plug the loopback test board (Agilent part number E3496-66502) directly into the emulation module. Do not plug anything into the other end of the loopback test board.

On a good system, the RESET LED will light and the BKG and USER LEDs will be out.

- 2 telnet to the emulation module.
- 3 Enter the **pv 1** command.

See Also

Options available for the "pv" command are explained in the help screen displayed by typing "help pv" or "? pv" at the prompt. Note, however, that some of the options listed may not apply to your emulation module.

Examples:

If you are using a UNIX system, to telnet to a logic analysis system named "mylogic", enter:

```
telnet mylogic 6472
```

Here are some examples of ways to use the **pv** command.

To execute both tests one time:

```
pv 1
```

To execute test 2 with maximum debug output repeatedly until a ^C is entered:

```
pv -t2 -v9 0
```

To execute tests 3, 4, and 5 only for 2 cycles:

```
pv -t3-5 2
```

The results on a good system with the loopback test board connected, are as follows:

```
M>pv 1
```

```
Testing: E3499C Series Emulation System
Test  1: Powerup PV Results                Passed!
Test  2: Target Probe Feedback Test        Passed!
Test  3: Boundary Scan Master Test         Passed!
Test  4: I2C Test                          Passed!
Test  5: Data Lines Test                   Passed!
PASSED  Number of tests: 1                  Number of failures: 0
```

Copyright (c) Agilent Technologies 1987
All Rights Reserved. Reproduction, adaptation, or translation without prior written permission is prohibited, except as allowed under copyright laws.

Chapter 9: Troubleshooting the Emulation Module
Problems with the Emulation Module

E3499C Series Emulation System
Version: A.07.51 17Dec97
Location: Generics

E3468A Toshiba TX19/39 Series Emulator
Version: A.01.00 Jan 99

M>

Problem with the Trace Port Analyzer and TIM

To perform the TIM and Trace Port Analyzer PV tests with an emulation probe/module

- 1 End any Emulation Control Interface or debugger sessions.
- 2 Disconnect the 20-pin cable from a target system, and plug the target end of 20-pin cable into loop-back connector on a TIM.

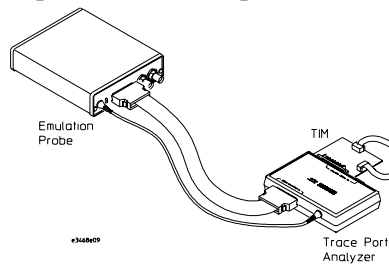

- 3 Telnnet to the emulation probe/module.
- 4 Enter **pv 1** command.

The result will appear on screen as below.

```
Testing: E3499B Series Emulation System
  Test  1: Powerup PV Results                Passed!
  Test  2: LAN 10Base2 Feedback Test         Not Executed!
  Test  3: LAN 10BaseT Feedback Test         Not Executed!
  Test  4: Break In and Trigger Out BNC Feedback Test Passed!
  Test  5: Target Probe Feedback Test        Not Executed!
  Test  6: Boundary Scan Master Test         Not Executed!
  Test  7: I2C Test                          Not Executed!
  Test  8: Data Lines Test                   Passed!
Testing: E3468A Toshiba TX19/39 Series Emulator
  Test  1: E3468 TIM/TP Test                 Passed!
PASSED  Number of tests: 1                   Number of failures: 0
```

Copyright (c) Agilent Technologies 1987
All Rights Reserved. Reproduction, adaptation, or translation without prior
written permission is prohibited, except as allowed under copyright laws.

Chapter 9: Troubleshooting the Emulation Module
Problem with the Trace Port Analyzer and TIM

E3499B Series Emulation System
Version: A.07.07 06Jul98 12:56 Proto
Location: Generics

E3468A Toshiba TX19/39 Series Emulator
Version: A.01.00 Jan 99

To perform the TIM only PV tests with an emulation probe/module

- 1 End any Emulation Control Interface or debugger sessions.
- 2 Disconnect the trace port analyzer, and connect a TIM to 50-pin cable directly.
- 3 Plug the target end of 20-pin cable into loop-back connector on a TIM.

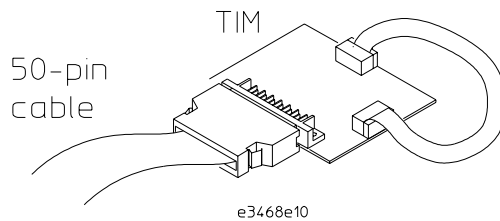

- 4 Telnet to the emulation probe/module.
- 5 Enter **pv 1** command.

The result will appear on screen as below.

```
Testing: E3499B Series Emulation System
Test 1: Powerup PV Results           Passed!
Test 2: LAN 10Base2 Feedback Test    Not Executed!
Test 3: LAN 10BaseT Feedback Test    Not Executed!
Test 4: Break In and Trigger Out BNC Feedback Test Passed!
Test 5: Target Probe Feedback Test   Not Executed!
Test 6: Boundary Scan Master Test    Not Executed!
Test 7: I2C Test                     Not Executed!
Test 8: Data Lines Test              Passed!
Testing: E3468A Toshiba TX19/39 Series Emulator
Test 1: E3468 TIM Test                Passed!
PASSED Number of tests: 1             Number of failures: 0
```

Copyright (c) Agilent Technologies 1987
All Rights Reserved. Reproduction, adaptation, or translation without prior written permission is prohibited, except as allowed under copyright laws.

E3499B Series Emulation System
Version: A.07.07 06Jul98 12:56 Proto
Location: Generics

E3468A Toshiba TX19/39 Series Emulator
Version: A.01.00 Jan 99

If a performance verification test fails

- Details of the failure can be obtained through using a -v option ("verbose" level) of 2 or more.
- Check that the loopback test board is connected.
- If the problem persists, contact Agilent Technologies for assistance.

Returning Parts to Agilent Technologies for Service

The repair strategy for this emulation solution is board replacement.

Exchange assemblies are available when a repairable assembly is returned to Agilent Technologies. These assemblies have been set up on the "Exchange Assembly" program. This lets you exchange a faulty assembly with one that has been repaired, calibrated, and performance verified by the factory. The cost is significantly less than that of a new assembly.

To return a part to Agilent Technologies

- 1** Follow the procedures in this chapter to make sure that the problem is caused by a hardware failure, not by configuration or cabling problems.
- 2** In the U.S., call 1-800-403-0801. Outside the U.S., call your nearest Agilent Technologies sales office. Ask them for the address of the nearest Agilent Technologies service center.
- 3** Package the part and send it to the Agilent Technologies service center.
Keep any parts which you know are working. For example, if only the target interface module is broken, keep the emulation module and cables.
- 4** When the part has been replaced, it will be sent back to you.
The unit returned to you will have the same serial number as the unit you sent to Agilent Technologies.

The Agilent Technologies service center can also troubleshoot the hardware and replace the failed part. To do this, send your entire measurement system to the service center, including the logic analysis system, target interface module, and cables.

In some parts of the world, on-site repair service is available. Ask an Agilent Technologies sales or service representative for details.

To obtain replacement parts

The following table lists some parts that may be replaced if they are damaged or lost. The part numbers are subject to change. Contact your nearest Agilent Technologies Sales Office for further information.

Part numbers

Exchange Assemblies

Part Number	Description
16600-69515	Emulation module
E3468-66401	Programmed emulation probe assembly

Replacement Assemblies

Part Number	Description
E3492-61601	20-pin target cable
E3496-61601	50-pin cable
E3496-66502	Loopback test board
E3468-66501	Target Interface Module
16700-61608	Expansion cable for emulation module
0950-3043	Power supply for emulation probe
E5890-64301	Trace Port Analyzer
E5890-66502	Trace Port Analyzer loopback test board

Cleaning the Instrument

If the instrument requires cleaning:

- 1 Remove power from the instrument.
- 2 Clean the instrument with a mild detergent and water.
- 3 Make sure that the instrument is completely dry before reconnecting it to a power source.

Glossary

Analysis Probe

A probing solution connected to the target microprocessor. It provides an interface between the signals of the target microprocessor and the inputs of the logic analyzer. Formerly called a "preprocessor."

Elastomeric Probe Adapter

A connector that is fastened on top of a target microprocessor using a retainer and knurled nut. The conductive elastomer on the bottom of the probe adapter makes contact with pins of the target microprocessor and delivers their signals to connection points on top of the probe adapter.

Emulation Module

An emulation module is installed within the mainframe of a logic analyzer. It provides run control within an emulation and analysis test setup. See Emulation Probe.

Emulation Probe

An emulation probe is a standalone instrument connected to the mainframe of a logic analyzer. It provides run control within an emulation and analysis test setup. Formerly called a

"processor probe" or "software probe." See Emulation Module.

Extender

A part whose only function is to provide connections from one location to another. One or more extenders might be stacked to raise a probe above a target microprocessor to avoid mechanical contact with other components installed close to the target microprocessor. Sometimes called a "connector board."

Flexible Adapter

Two connection devices coupled with a flexible cable. Used for connecting probing hardware on the target microprocessor to the analysis probe.

General-Purpose Flexible Adapter

A cable assembly that connects the signals from an elastomeric probe adapter to an analysis probe. Normally, a male-to-male header or transition board makes the connections from the general-purpose flexible adapter to the analysis probe.

High-Density Adapter Cable

A cable assembly that delivers signals from an analysis probe hardware

interface to the logic analyzer pod cables. A high-density adapter cable has a single Mictor connector that is installed into the analysis probe, and two cables that are connected to corresponding odd and even logic analyzer pod cables.

High-Density Termination Adapter Cable

Same as a High-Density Adapter Cable, except it has a termination in the Mictor connector.

Jumper

Moveable direct electrical connection between two points.

Mainframe Logic Analyzer

A logic analyzer that resides on one or more board assemblies installed in an Agilent Technologies 16500, 1660x, or 16600A/700A-series mainframe.

Male-to-male Header

A board assembly that makes point-to-point connections between the female pins of a flexible adapter or transition board and the female pins of an analysis probe.

Preprocessor

See Analysis Probe.

Preprocessor Interface

See Analysis Probe.

Probe adapter

See Elastomeric Probe Adapter.

Processor Probe

See Emulation Probe.

Prototype Analyzer

The Agilent Technologies 16505A prototype analyzer acts as an analysis and display processor for the Agilent Technologies 16500B/C logic analysis system. It provides a windowed interface and powerful analysis capabilities. Replaced by Agilent Technologies 16600A/700A-series logic analysis systems.

Run Control Probe

See Emulation Probe and Emulation Module.

Setup Assistant

A software program that guides a user through the process of connecting and configuring a logic analyzer to make measurements on a specific microprocessor.

Shunt Connector.

See Jumper.

Software Probe

See Emulation Probe.

Solution

Agilent Technologies' term for a set of tools for debugging your target system. A solution includes probing, inverse assembly, the Agilent Technologies B4620B Source Correlation Tool Set, and possibly an emulation module.

Glossary

Stand-alone Logic Analyzer

A standalone logic analyzer has a predefined set of hardware components which provide a specific set of capabilities. It is designed to perform logic analysis. A standalone logic analyzer differs from a mainframe logic analyzer in that it does not offer card slots for installation of additional capabilities, and its specifications are not modified based upon selection from a set of optional hardware boards that might be installed within its frame.

Target Control Port

An 8-bit, TTL port on a logic analysis system that you can use to send signals to your target system. It does not function like a pattern generator or emulation module, but more like a remote control for the target's switches.

Target Interface Module

A small circuit board which connects the 50-pin cable from an emulation module or emulation probe to signals from the debug port on a target system.

TIM

See Target Interface Module.

Trace Port Analyzer

A small logic analyzer which was specialized for PC-Trace function dedicated in Tx19/39 series processors.

Trigger Specification

A set of conditions that must be true before the instrument triggers. See the

printed or online documentation for your logic analyzer for details.

Transition Board

A board assembly that obtains signals connected to one side and rearranges them in a different order for delivery at the other side of the board.

1/4-Flexible Adapter

An adapter that obtains one-quarter of the signals from an elastomeric probe adapter (one side of a target microprocessor) and makes them available for probing.

Index

A

altitude specifications, 87
analysis probe
 connecting to, 70
 definition, 127
 overview, 2
 processors supported, 4
 product numbers, 4
analysis probe problems, 93
 erratic trace measurements, 94
 target system will not boot, 93
analyzer problems, 91
 capacitive loading, 94
 intermittent data errors, 91
 unwanted triggers, 91

B

BDM port
 See debug port
BKG light, 119
built-in commands
 list of commands, 109–111

C

cable
 power, 14, 47
cables
 emulator, 68
 replacing, 103, 125
cache
 trace problems and, 95
CD-ROM, installing software from, 30
checklist, setup, 13
cleaning, 103, 126
clocks
 slow, 100
configuration
 flowchart, 13
configuration files
 installing, 27, 29–30
connection
 emulation module, 53–54, 59–60
 problems, LAN, 116
connector board, 127

D

debug port
 connecting to, 68

debuggers

 writing, 111
development port
 See debug port
direct probing, 45
directories
 software installation, 30
driver firmware error, 114

E

elastomeric probe adapter
 definition, 127
emulation module
 16600 installation, 57
 16700A installation, 55
 connecting, 54–58, 60, 67–70
 definition, 127
 description of, 3
 product numbers, 4
 target system design, 64–66
emulation probe
 definition, 127
emulation solution
 See solution
equipment required
 emulation module, 21
 trace port analyzer, 23
equipment supplied
 emulation module, 20–21
 ordering information, 4
 overview, 4
 trace port analyzer, 22–23
error messages
 inverse assembler, 98
extender, 127

F

files
 loading vs. installing, 28
flexible adapter
 definition, 127
flowchart, setup, 13

G

general-purpose flexible adapter
 definition, 127
general-purpose probes, 45

H

high-density adapter cable
 definition, 127
high-density termination adapter cable
 definition, 128

I

information sources, 26
init command, 114
installation, software, 27, 29–30
instruction cache
 cache, 95
intermodule measurement problems, 97
 an event wasn't captured, 97
inverse assembler problems, 95
 incorrect inverse assembly, 95
 no inverse assembly, 95

J

jumper, definition, 128

L

LAN
 problems, 116–117
lights
 See status lights
listing
 incorrect, 95
loading configurations, vs. installing, 27, 29–30

M

mainframe logic analyzer
 definition, 128
male-to-male header
 definition, 128
mask, subnet, 117
microprocessors supported, 4

P

performance verification test, 118
port number, emulation module, 109
power cord, ??–14, ??–47
preprocessor
 See analysis probe
problems
 emulation module, 105–126

processor support package, 30
 processors supported, 4
 prompts, 111
 list of, 111
 troubleshooting, 114
 prototype analyzer
 definition, 128
 PV
 See performance verification test

R
 references, 26
 register commands, 112
 repair
 analysis probe, 102
 emulation module, 124–126
 requirements
 target system, 64–66
 RESET
 light, 108
 signal, 64
 run control tool
 See emulation control interface

S
 service, how to obtain, 102, 124
 setup assistant
 definition, 128
 setup checklist, 13
 slow clock, 107
 software
 installing, 27
 list of installed, 29
 software probe
 See emulation module
 See emulation probe
 solution
 at a glance, 2
 definition, 128
 solutions
 description of, 2
 product numbers, 4
 specifications
 altitude, 87
 temperature, 87
 status lights, 108–??
 subnet mask, 117

T
 target control port, 129
 target interface module (TIM)
 connecting, 68
 definition, 129
 target system
 boot failure, 93
 connecting to, 54–58, 60
 designing for Agilent Technologies
 E2477A software, 44
 problems with, 112–115
 requirements for emulation, 64–66
 telnet, 109
 temperature specifications, 87
 terminal interface
 See also built-in commands
 tests, emulation module, 118–123
 trace
 erratic, 94
 missing display, 92
 trace port analyzer
 definition, 129
 product numbers, 4
 transition board
 definition, 129
 trigger
 unwanted, 91
 troubleshooting, 107
 analysis probe, 90
 emulation module, 105–126
 turning on power, 14, 47

U
 USER light, 108–??

W
 web sites
 logic analyzers, 26

DECLARATION OF CONFORMITY

according to ISO/IEC Guide 22 and EN 45014

Manufacturer's Name: Agilent Technologies
Manufacturer's Address: Digital Design Product Generation Unit
1900 Garden of the Gods Road
Colorado Springs, CO 80907 USA

declares, that the product

Product Name: Trace Port Analyzer
Model Number(s): Agilent Technologies E5903A
Product Option(s): All

conforms to the following Product Specifications:

Safety: EN 61010-1:1993 / IEC 1010-1:1990+A1
UL 3111
CSA-C22.2 No. 1010.1:1993

EMC: EN 55011:1991 / CISPR 11:1990 - Group 1 Class A
IEC 555-2:1982 + A1:1985 / EN 60555-2:1987
IEC 555-3:1982 + A1:1990 / EN 60555-3:1987 + A1:1991
IEC 801-2:1991 / EN 50082-1:1992 4 kV CD, 8 kV AD
IEC 801-3:1984 / EN 50082-1:1992 3 V/m, {1kHz 80% AM, 27-1000 MHz}
IEC 801-4:1988 / EN 50082-1:1992 0.5 kV Sig. Lines, 1 kV Power Lines

Supplementary Information:

The product herewith complies with the requirements of the Low Voltage Directive 73/23/EEC and the EMC Directive 89/336/EEC and carries the CE marking accordingly.

This product was tested in a typical configuration with Agilent Technologies test systems.

Colorado Springs, 08/10/98



Ken Wyatt / Product Regulations Manager

European Contact: Your local Agilent Technologies Sales and Service Office or Agilent Technologies GmbH, Department ZQ / Standards Europe, Herrenberger Strasse 130, D-71034 Böblingen Germany (FAX: +49-7031-14-3143)

Product Regulations

Safety IEC 1010-1:1990+A1 / EN 61010-1:1993
CSA-C22.2 No. 1010.1:1993

EMC This Product meets the requirement of the European Communities (EC) EMC Directive 89/336/EEC.



ISM 1-A

Emissions EN55011/CISPR 11 (ISM, Group 1, Class A equipment)
EN60555-2 / IEC555-2
EN60555-3 / IEC555-3

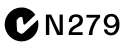

Immunity		Code ¹	Notes ²
EN50082-1			
IEC 801-2 (ESD) 4kV CD, 8kV AD		1	
IEC 801-3 (Rad.) 3 V/m		1	
IEC 801-4 (EFT) 0.5 kV, 1kV			

¹Performance Codes:

1 PASS - Normal operation, no effect.

2 PASS - Temporary degradation, self recoverable.

3 PASS - Temporary degradation, operator intervention required.

4 FAIL - Not recoverable, component damage.

²Notes: (none)

Sound Pressure Level N/A

DECLARATION OF CONFORMITY

according to ISO/IEC Guide 22 and EN 45014

Manufacturer's Name: Agilent Technologies
Manufacturer's Address: Digital Design Product Generation Unit
1900 Garden of the Gods Road
Colorado Springs, CO 80907 USA

declares, that the product

Product Name: Logic Analyzer Mainframe
Model Number(s): Agilent Technologies 16700A
Product Option(s): All

conforms to the following Product Specifications:

Safety: IEC 1010-1:1990+A1 / EN 61010-1:1993
UL3111
CSA-C22.2 No. 1010.1:1993

EMC: CISPR 11:1990 / EN 55011:1991 Group 1 Class A
IEC 555-2:1982 + A1:1985 / EN 60555-2:1987
IEC 555-3:1982 + A1:1990 / EN 60555-3:1987 + A1:1991
IEC 801-2:1991 / EN 50082-1:1992 4 kV CD, 8 kV AD
IEC 801-3:1984 / EN 50082-1:1992 3 V/m, {1kHz 80% AM, 27-1000 MHz}
IEC 801-4:1998 / EN 50082-1:1992 0.5 kV Sig. Lines, 1 kV Power Lines

Supplementary Information:

The product herewith complies with the requirements of the Low Voltage Directive 73/23/EEC and the EMC Directive 89/336/EEC and carries the CE marking accordingly.

This product was tested in a typical configuration with Agilent Technologies test systems.

Colorado Springs, 09/22/97

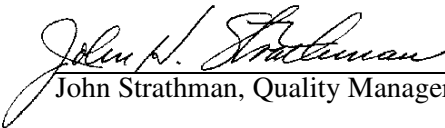
John Strathman, Quality Manager

European Contact: Your local Agilent Technologies Sales and Service Office or Agilent Technologies GmbH, Department ZQ / Standards Europe, Herrenberger Strasse 130, D-71034 Böblingen Germany (FAX: +49-7031-14-3143)

Product Regulations

Safety IEC 1010-1:1990+A1 / EN 61010-1:1993
UL3111
CSA-C22.2 No. 1010.1:1993

EMC This Product meets the requirement of the European Communities (EC) EMC Directive 89/336/EEC.



Emissions EN55011/CISPR 11 (ISM, Group 1, Class A equipment),
IEC 555-2 and IEC 555-3

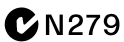

Immunity	EN50082-1	Code ¹	Notes ²
	IEC 801-2 (ESD) 4kV CD, 8kV AD	3	1
	IEC 801-3 (Rad.) 3 V/m	3	
	IEC 801-4 (EFT) 0.5 kV, 1kV		

¹Performance Codes:

1 PASS - Normal operation, no effect.

2 PASS - Temporary degradation, self recoverable.

3 PASS - Temporary degradation, operator intervention required.

4 FAIL - Not recoverable, component damage.

²Notes: (none)

Sound Pressure Level Less than 60 dBA

DECLARATION OF CONFORMITY

according to ISO/IEC Guide 22 and EN 45014

Manufacturer's Name: Agilent Technologies
Manufacturer's Address: Digital Design Product Generation Unit
1900 Garden of the Gods Road
Colorado Springs, CO 80907 USA

declares, that the product

Product Name: Logic Analyzer
Model Number(s): Agilent Technologies 16600A, 16601A, 16602A,
16603A
Product Option(s): All

conforms to the following Product Specifications:

Safety: IEC 1010-1:1990+A1 / EN 61010-1:1993
UL3111
CSA-C22.2 No. 1010.1:1993

EMC: CISPR 11:1990 / EN 55011:1991 Group 1 Class A
IEC 555-2:1982 + A1:1985 / EN 60555-2:1987
IEC 555-3:1982 + A1:1990 / EN 60555-3:1987 + A1:1991
IEC 801-2:1991 / EN 50082-1:1992 4 kV CD, 8 kV AD
IEC 801-3:1984 / EN 50082-1:1992 3 V/m, { 1kHz 80% AM, 27-1000 MHz }
IEC 801-4:1998 / EN 50082-1:1992 0.5 kV Sig. Lines, 1 kV Power Lines

Supplementary Information:

The product herewith complies with the requirements of the Low Voltage Directive 73/23/EEC and the EMC Directive 89/336/EEC and carries the CE marking accordingly.

This product was tested in a typical configuration with Agilent Technologies test systems.

Colorado Springs, 08/18/97

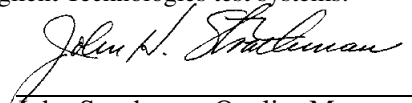
John Strathman, Quality Manager

European Contact: Your local Agilent Technologies Sales and Service Office or Agilent Technologies GmbH, Department ZQ / Standards Europe, Herrenberger Strasse 130, D-71034 Böblingen Germany (FAX: +49-7031-14-3143)

Product Regulations

Safety IEC 1010-1:1990+A1 / EN 61010-1:1993
UL3111
CSA-C22.2 No. 1010.1:1993

EMC This Product meets the requirement of the European Communities (EC) EMC Directive 89/336/EEC.



Emissions EN55011/CISPR 11 (ISM, Group 1, Class A equipment),
IEC 555-1 and IEC 555-2

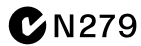

Immunity	EN50082-1	Code ¹	Notes ²
	IEC 801-2 (ESD) 4kV CD, 8kV AD	3	1
	IEC 801-3 (Rad.) 3 V/m	3	
	IEC 801-4 (EFT) 0.5 kV, 1kV		

¹Performance Codes:

1 PASS - Normal operation, no effect.

2 PASS - Temporary degradation, self recoverable.

3 PASS - Temporary degradation, operator intervention required.

4 FAIL - Not recoverable, component damage.

²Notes: (none)

Sound Pressure Level Less than 60 dBA

©Copyright Agilent Technologies 1994-2000

All Rights Reserved. Reproduction, adaptation, or translation without prior written permission is prohibited, except as allowed under the copyright laws.

Restricted Rights Legend

Use, duplication, or disclosure by the U.S. Government is subject to restrictions set forth in subparagraph (C) (1) (ii) of the Rights in Technical Data and Computer Software Clause in DFARS 252.227-7013.

Agilent Technologies, 3000 Hanover Street, Palo Alto, CA 94304 U.S.A.

Rights for non-DOD U.S. Government Departments and Agencies are set forth in FAR 52.227-19(c)(1,2).

Document Warranty

The information contained in this document is subject to change without notice.

Agilent Technologies makes no warranty of any kind with regard to this material, including, but not limited to, the implied warranties of merchantability or fitness for a particular purpose.

Agilent Technologies shall not be liable for errors contained herein or for damages in connection with the furnishing, performance, or use of this material.

Safety

• This apparatus has been designed and tested in accordance with IEC Publication 1010, Safety Requirements for Measuring Apparatus, and has been supplied in a safe condition. This is a Safety Class I instrument (provided with terminal for protective earthing). Before applying power, verify that the correct safety precautions are taken (see the following warnings). In addition, note the external markings on the instrument that are described under "Safety Symbols."

Warning

- Before turning on the instrument, you must connect the protective earth terminal of the instrument to the protective conductor of the (mains) power cord. The mains plug shall only be inserted in a socket outlet provided with a protective earth contact. You must not negate the protective action by using an extension cord (power cable) without a protective conductor (grounding). Grounding one conductor of a two-conductor outlet is not sufficient protection.
- Only fuses with the required rated current, voltage, and specified type (normal blow, time delay, etc.) should be used. Do not use repaired fuses or short-circuited fuseholders. To do so could cause a shock or fire hazard.

- Service instructions are for trained service personnel. To avoid dangerous electric shock, do not perform any service unless qualified to do so. Do not attempt internal service or adjustment unless another person, capable of rendering first aid and resuscitation, is present.
- If you energize this instrument by an auto transformer (for voltage reduction), make sure the common terminal is connected to the earth terminal of the power source.
- Whenever it is likely that the ground protection is impaired, you must make the instrument inoperative and secure it against any unintended operation.
- Do not operate the instrument in the presence of flammable gasses or fumes. Operation of any electrical instrument in such an environment constitutes a definite safety hazard.
- Do not install substitute parts or perform any unauthorized modification to the instrument.
- Capacitors inside the instrument may retain a charge even if the instrument is disconnected from its source of supply.
- Use caution when exposing or handling the CRT. Handling or replacing the CRT shall be done only by qualified maintenance personnel.

Safety Symbols



Instruction manual symbol: the product is marked with this symbol when it is necessary for you to refer to the instruction manual in order to protect against damage to the product.



Hazardous voltage symbol.



Earth terminal symbol: Used to indicate a circuit common connected to grounded chassis.

WARNING

The Warning sign denotes a hazard. It calls attention to a procedure, practice, or the like, which, if not correctly performed or adhered to, could result in personal injury. Do not proceed beyond a Warning sign until the indicated conditions are fully understood and met.

CAUTION

The Caution sign denotes a hazard. It calls attention to an operating procedure, practice, or the like, which, if not correctly performed or adhered to, could result in damage to or destruction of part or all of the product. Do not proceed beyond a Caution symbol until the indicated conditions are fully understood or met.

Agilent Technologies
P.O. Box 2197
1900 Garden of the Gods Road
Colorado Springs, CO 80901

Product Warranty

This Agilent Technologies product has a warranty against defects in material and workmanship for a period of one year from date of shipment. During the warranty period, Agilent Technologies will, at its option, either repair or replace products that prove to be defective.

For warranty service or repair, this product must be returned to a service facility designated by Agilent Technologies.

For products returned to Agilent Technologies for warranty service, the Buyer shall prepay shipping charges to Agilent Technologies and Agilent Technologies shall pay shipping charges to return the product to the Buyer. However, the Buyer shall pay all shipping charges, duties, and taxes for products returned to Agilent Technologies from another country.

Agilent Technologies warrants that its software and firmware designated by Agilent Technologies for use with an instrument will execute its programming instructions when properly installed on that instrument. Agilent Technologies does not warrant that the operation of the instrument software, or firmware will be uninterrupted or error free.

Limitation of Warranty

The foregoing warranty shall not apply to defects resulting from improper or inadequate maintenance by the Buyer, Buyer-supplied software or interfacing, unauthorized modification or misuse, operation outside of the environmental specifications for the product, or improper site preparation or maintenance.

No other warranty is expressed or implied. Agilent Technologies specifically disclaims the implied warranties of merchantability or fitness for a particular purpose.

Exclusive Remedies

The remedies provided herein are the buyer's sole and exclusive remedies. Agilent Technologies shall not be liable for any direct, indirect, special, incidental, or consequential damages, whether based on contract, tort, or any other legal theory.

Assistance

Product maintenance agreements and other customer assistance agreements are available for Agilent Technologies products.

For any assistance, contact your nearest Agilent Technologies Sales Office.

Certification

Agilent Technologies certifies that this product met its published specifications at the time of shipment from the factory. Agilent Technologies further certifies that its calibration measurements are traceable to the United States National Institute of Standards and Technology, to the extent allowed by the Institute's calibration facility, and to the calibration facilities of other International Standards Organization members.

About this edition

This is the *Solutions for the Toshiba TMPR3903 User's Guide*.

Publication Number
E8025-97003, July 2000
Printed in USA.

The information in this manual previously appeared in:
E8025-97000, April 1999
E8025-97002, May 1999

New editions are complete revisions of the manual. Many product updates do not require manual changes; and, conversely, manual corrections may be done without accompanying product changes. Therefore, do not expect a one-to-one correspondence between product updates and manual updates.

UNIX is a registered trademark of The Open Group.

Windows, MS Windows, Windows NT, and MS-DOS are U.S. registered trademarks of Microsoft Corporation.

X/Open is a registered trademark, and the X device is a trademark of X/Open Company Ltd. in the UK and other countries.

Tx19/39 Embedded MIPS microprocessors are products of Toshiba, Inc.